

Zigbee Gateway User manual

SP1-zigbee-GW-W

User Manual

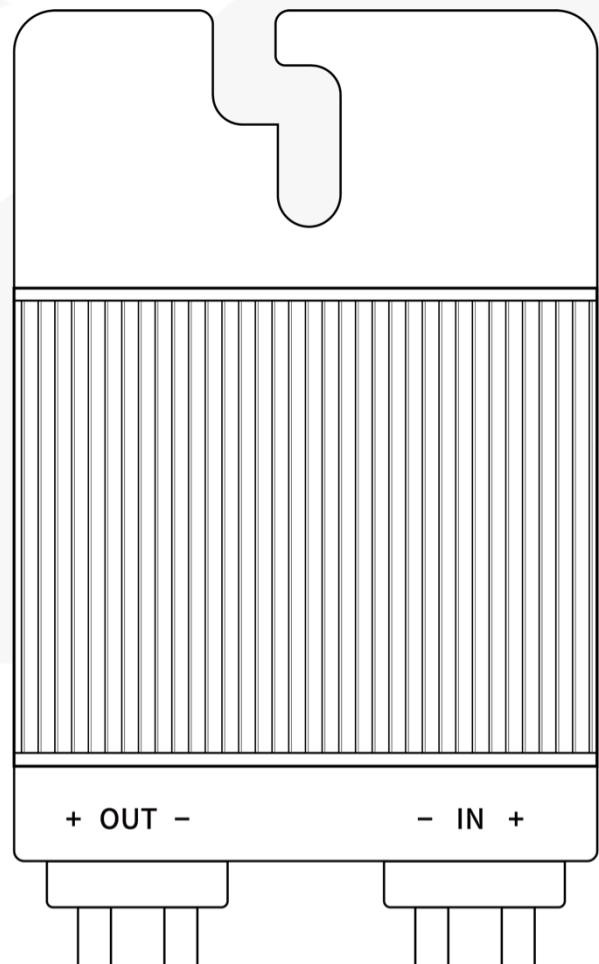

Copyright © SolarPilot Energy GmbH. 2023. All rights reserved.

No part of this document may be reproduced or transmitted in any form or by any means without prior written consent of SolarPilot Energy GmbH.

Important Notice

The purchased products, services and features are stipulated by the contract made between SolarPilot Energy GmbH and the customer. All or part of the products, services and features described in this document may not be within the purchase scope or the usage scope. Unless otherwise specified the contract, all statements, information, and recommendations in this document are provided "AS IS" without warranties, guarantees or representations of any kind, either express or implied.

The material furnished in this document is believed to be accurate and reliable. However, SolarPilot assumes no responsibility for the use of this material. SolarPilot reserves the right to make changes to the material at any time and without notice. You may refer to the SolarPilot web site (www.solarpilot.com) for the most updated version.

Trademarks and Permissions



And the SP trademarks used in this manual is owned by SolarPilot Energy GmbH.

All other trademarks or registered trademarks mentioned in this manual are the property of their respective owners.

Software Licensing

It is prohibited to use some or all of the data in the firmware or software developed by the company for commercial purposes in any way.

It is forbidden to reverse compile, decrypt or otherwise destroy the original program design of the software developed by the company.

SolarPilot Energy GmbH

Address: Arndtstrasse 27b, 22085 Hamburg, Germany

E-mail: info@solarpilot.com

Telephone: [+86 0751-88779861](tel:+86075188779861)

Website: <https://www.solarpilot.com>

About This Manual

This document mainly introduces the functional characteristics, electrical parameters, product structure and other contents of the Zigbee gateway.

The pictures in this article are for reference only. Please refer to the actual product for details.

The content of the manual will be constantly updated and revised, but it is inevitable that there will be slight discrepancies or errors with the actual product.

Users should refer to the purchased product, and can download the latest version of the manual through www.solarpilot.com or sales channels.

Scope of application

This manual is mainly aimed at the following products:

Zigbee Gateway (SP1-zigbee-GW-W)

In the following text, unless otherwise specified, it is referred to as "Gateway".

Intended Readers

- Sales engineers
- Technical support engineers
- Hardware installation engineers
- Maintenance engineer

Directory

1 Introduction	1
1.1 Product Introduction	1
1.2 Product features	1
2 Interface	2
2.1 Wiring topology	2
2.2 Interface location	2
2.3 Interface description	3
3 Buttons and indicator lights	4
3.1 Button and indicator light position	4
3.2 Button and indicator light instructions	4
4 Unpacking and storage	5
4.1 Unpacking and inspection	5
4.2 Identify the gateway	5
4.3 Scope of supply	6
4.4 Gateway storage	7
5 Installation	8
5.1 Preparation	8
5.2 Choose the appropriate location	8
5.3 Wiring	8
5.4 Box back panel	8
5.5 Connect the network cable	9
5.6 Fixed Gateway	9
6 APP operation Find	10
6.1 Download the APP	10
6.2 Registration and Login	10

6.3 Create a Power Station	11
6.4 Add Layout	18
6.5 Improve the information	19
7 Replace the gateway	21
7.1 Prerequisite conditions	21
7.2 Operation steps	21
8 Technical indicators	23

1 Introduction

1.1 Product Introduction

SP1-zigbee-GW series products are SolarPilot Data Acquisition products. They use a 2.4G wireless solution to collect information and data from on-site optimizers and send data to SolarPilot Cloud Computing Platform through Ethernet or Wi-Fi communication.

Through SP1-zigbee-GW-W, users can obtain component-level data and alarms, while achieving remote and local shutdown. Remote operation and maintenance of photovoltaic systems can be realized anytime and anywhere on the SolarPilot data platform.

SP1-zigbee-GW-W is used with SP1/SP2/SP3 series optimizers.

1.2 Product features

- Flexible and stable

Data upload supports Ethernet or Wi-Fi communication methods, and supports RS485 communication with external devices.

- Intelligent operation and maintenance

Implement component-level monitoring and operation and maintenance functions, simulate actual component layout, and dynamically display component status.

- Second-level monitoring

Component parameters are collected every 60 seconds for real-time anomaly analysis.

- Quick shutdown

Quick shutdown can be achieved through local buttons or apps.

2 Interface

2.1 Wiring topology

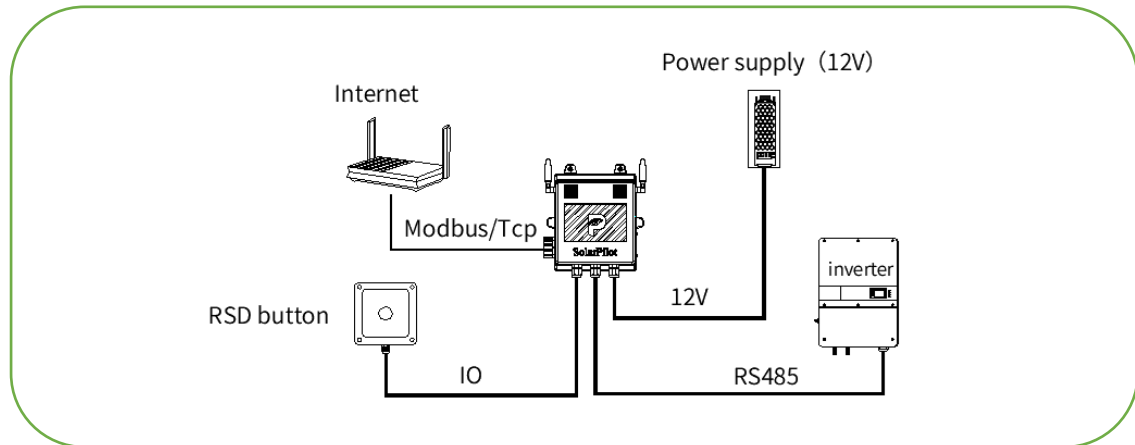

2.2 Interface location

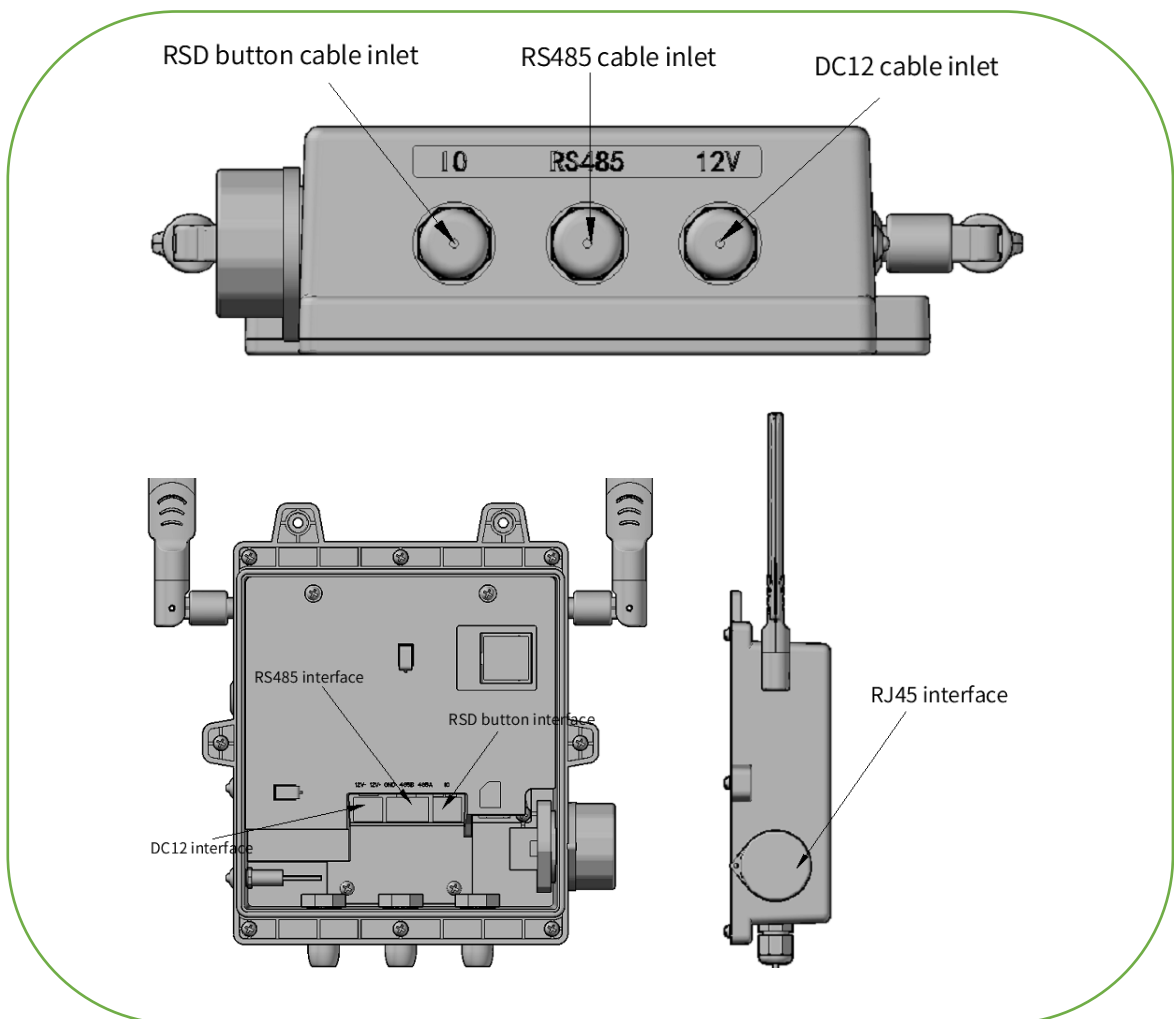

2.3 Interface description

2.3.1 Quick break button inlet

Connect the quick-break button cable inlet (if there is no quick-break button, it can be disconnected), and the cable interface can be connected to a cable diameter of 3-6.5mm.

2.3.2 Quick-break button interface

Connect the quick disconnect button, the IO port is the dry contact, and the wiring method is shown in the following figure.

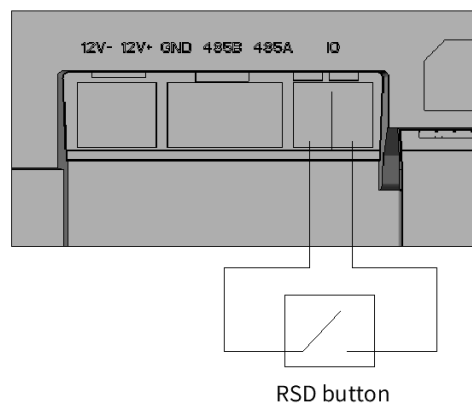

2.2.3 RS485 inlet

Connect to the cable inlet of RS485 equipment, and the cable interface can be connected with a cable diameter of 3~ 6.5mm. Currently, it supports inverter data access (if there is no RS485 device access, it can be disconnected).

2.2.4 RS485 Interfac

RS485 port distinguishes between RS485A, RS485B, and GND. When wiring, it needs to be aligned with the RS485A, RS485B, and GND of the inverter. The manufacturer, model specifications, and communication protocol of the inverter need to be sent to the after-sales operation and maintenance personnel. The inverter data can only be seen after the after-sales operation and maintenance personnel have added it.

2.2.5 DC12V inlet

Gateway DC12V power supply line inlet, cable interface can be connected to cable diameter of 3~ 6.5mm.

2.2.6 DC12V interface

Provide stable power to the gateway, pay attention to the positive and negative poles when accessing, otherwise it will cause the device to malfunction.

2.2.7 RJ45 interface

Provide a stable network interface to the gateway.

3 Buttons and indicator lights

3.1 Button and indicator light position

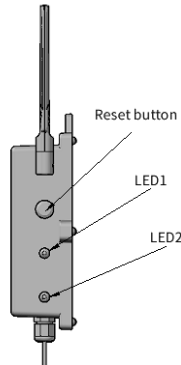

3.2 Button and indicator light instructions

3.2.1 Buttons

AP distribution network and gateway restart function

Serial number	Operating steps	Gateway is in state
1	Long press for 3-10 seconds	Activate AP distribution network
2	Long press for ≥ 10 seconds	Restart Gateway

3.2.2 LED1

Gateway network status indicator light, flashing status and gateway status are shown in the following table:

Serial number	Flashing indicator light condition	Gateway status
1	Flash mob	Unable to connect to the cloud
2	Always bright	Connect to the IOT server normally, and flash when you receive a message from the platform
3	Slow flash	AP distribution network

3.2.3 LED2

Serial number	Flashing indicator light condition	Gateway status
1	Always bright	The power supply is normal
2	Constant extinction	The power supply is abnormal

4 Unpacking and storage

4.1 Unpacking and inspection

The gateway has been fully tested and strictly inspected before leaving the factory, but there may still be damage during transportation. Please conduct a detailed inspection before signing for the product.

- Inspect the packaging box for damage.
- Check whether the goods are complete and match the order according to the packing list.
- Unpack and check if all internal equipment is intact.

If any damage is found, please contact the transportation company or directly contact SolarPilot Company and provide photos of the damaged area for easy service. Do not discard the original packaging of the gateway. It is best to store it in the original packaging box after the gateway is shut down and dismantled.

4.2 Identify the gateway

The back of the gateway is pasted with a nameplate. The nameplate provides the model information of the gateway, as well as the most important parameters and certification marks.

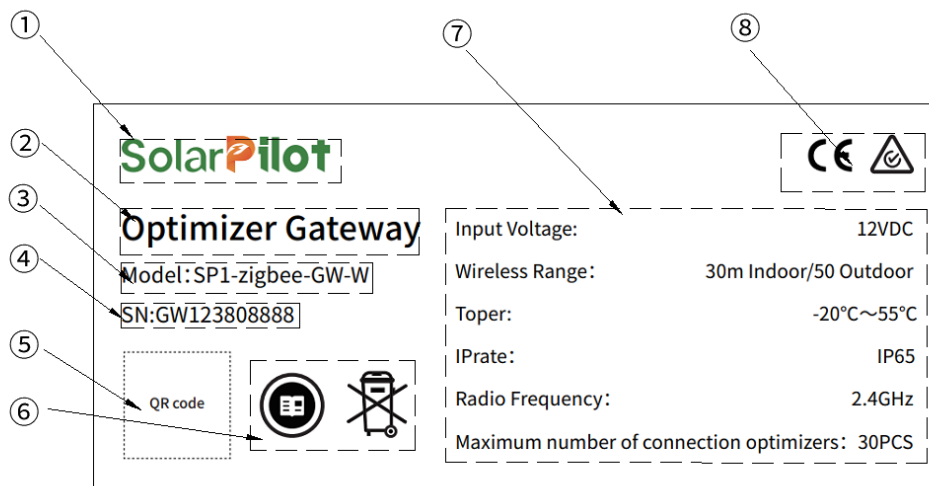

Serial number	Explanation
1	SolarPilot trademark
2	Gateway product name
3	Gateway model specification
4	Gateway SN code
5	Product SN QR code
6	Related identification

7	Related parameters
8	Related Certification

Nameplate identification instructions

	Read the instruction
	WEEE recycling logo

Certification Instructions

	Compliant with TUV certification mark
	Comply with CE certification mark

4.3 Scope of supply

Gateway×1	Quick Installation Manual×1	Certificate of conformity×1
Expansion screwdriver sleeve×2	RJ45 waterproof plug×1	Bolt ×8

4.4 Gateway storage

If the gateway is not used immediately, it needs to be stored in a specific environment :

- Storage temperature range -20 °C~ 55 °C, relative humidity range 0~ 95%, no condensation
- The storage time of the gateway is six months or more, and it needs to be comprehensively checked and tested by professionals before it can be put into operation.

5 Installation

5.1 Preparation

- Equipped with standard DC12V power supply
- Reliable wide network connection
- Router with Ethernet interface
- Installed the "Flywheel Intelligent Photovoltaic" APP

5.2 Choose the appropriate location

- Choose a location as close to the photovoltaic as possible, preferably within 30 meters of the photovoltaic module.
- The gateway can be directly installed on the outdoor wall. If it needs to be placed in the box, a plastic box should be used. It is prohibited to place it in a metal box, otherwise it will affect the communication function

5.3 Wiring

According to the on-site access situation of the project, reliably connect the corresponding cables from right to left, which are IO, RS485, and DC12V respectively. The wiring is shown in the following figure.

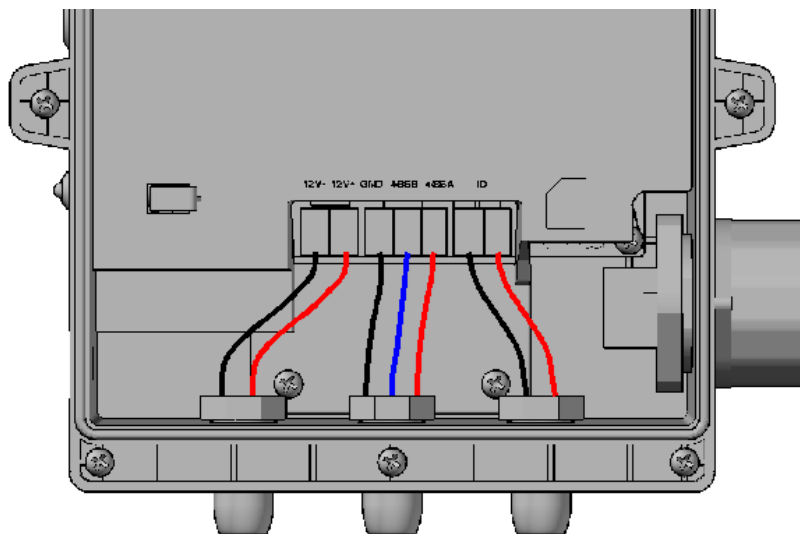

5.4 Box back panel

Fix the back panel with matching bolts (Note: 8 bolts must not be used less, and the bolts must be tightened in place, otherwise it will affect the waterproof performance).

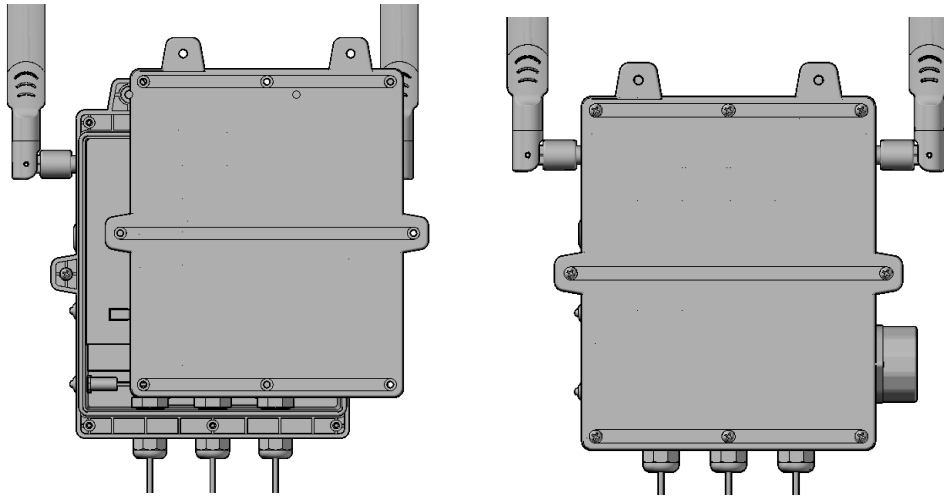

5.5 Connect the network cable

Use the matching RJ45 waterproof connector and follow the steps below.



Unscrew the RJ45 plug bottom cover



Insert the dialed network cable into the bottom cover

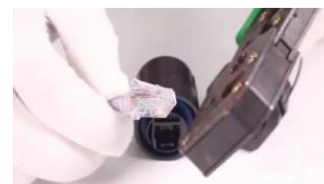

Press the mesh wire with crimping pliers



The network cable passes through the connector



Tighten the waterproof connector



Plug in with the gateway's socket

5.6 Fixed Gateway

The FL1-Zigbee-GW-W model gateway has a protection level of IP65, which can completely prevent dust and spray water from entering, but cannot be immersed in water.

It is recommended to hang the fixed gateway on the wall, and the distance from the nearest component should be $\leq 30m$.

6 APP operation Find

6.1 Download the APP

Method 1: Download from APP Store & Google Play.

iPhone mobile phone users: search for "SolarPilot smart photovoltaic" in the App Store.

Method 2: Download by scanning below QR code.

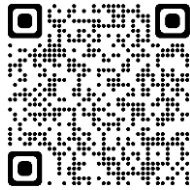

Android



IOS

Note: When you selecting "Browser download" method. If prompted "This application is from an unofficial app store..." and other prompts during the installation process, please click "Continue installation".

6.2 Registration and Login

Please follow the prompts, enter your mobile phone number or email account correctly and verify it. After passing the verification, complete the business information.

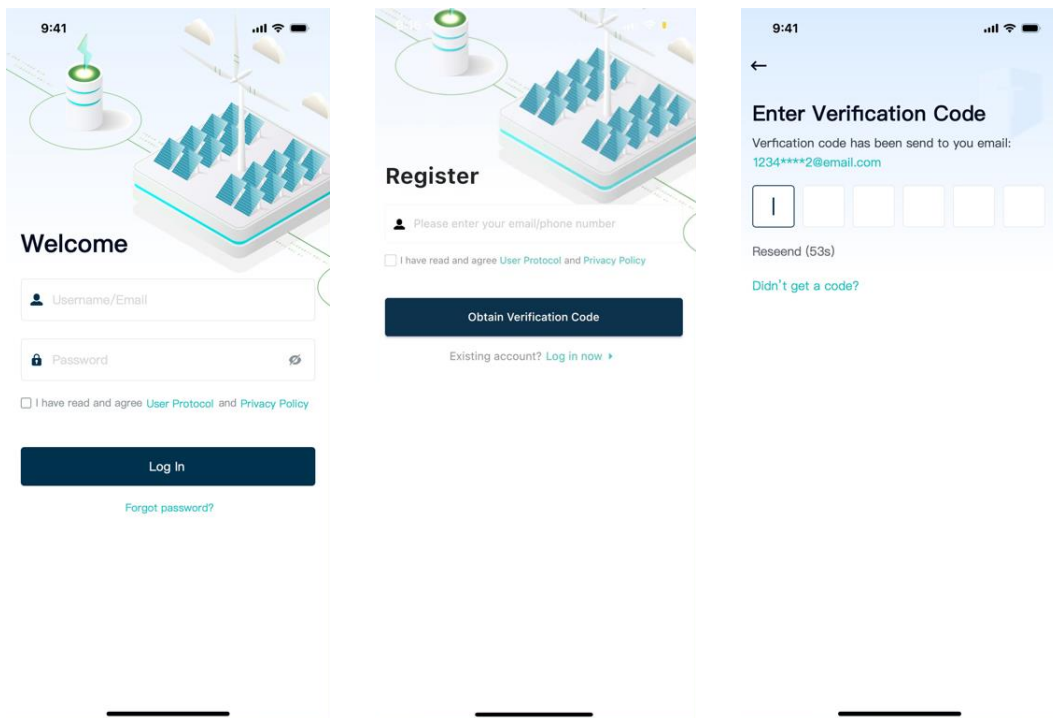

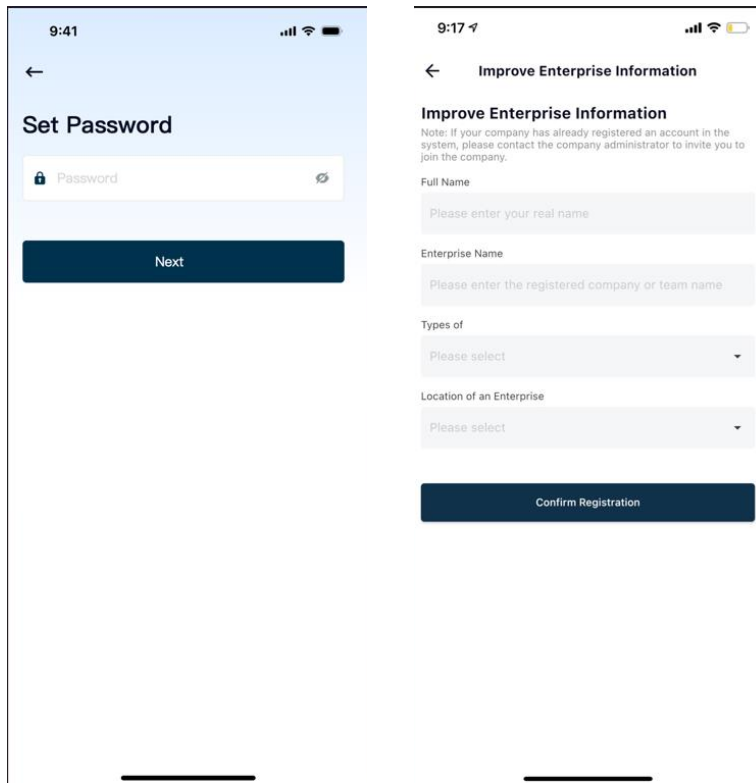

6.3 Create a Power Station

Step 1: Enter the power station addition page

Log in to the account you just created, and gradually click [My] - [Power Station Management] - [+] to enter the power station addition page.

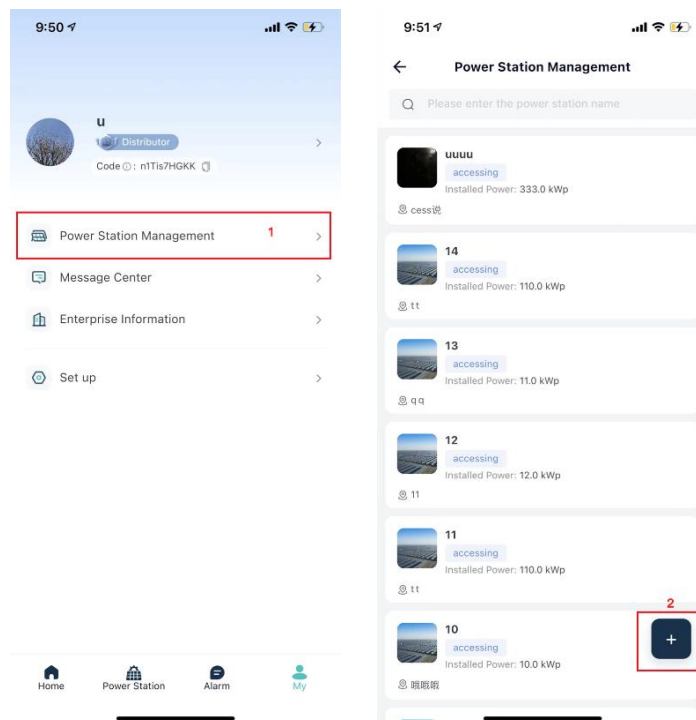

Step 2: Improve the power station information

- Please follow the prompts to improve the basic information of the power station: the name of the power station, the location of the power station, the area, the address, the installed power, etc. The fields indicated with an asterisk are required, and the more complete the rest of the information is, the better it is for you to manage the power station.

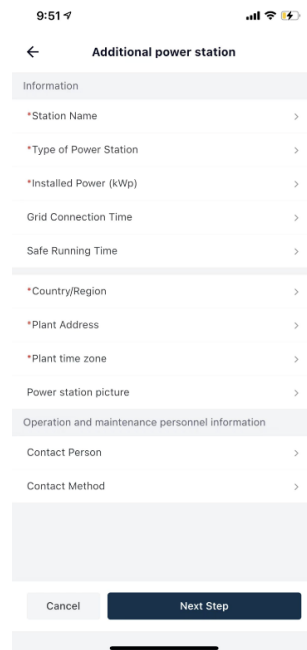

- After completing the power station information, please click the [Next] button at the bottom of the page to complete the creation, and the system will enter the interface of Figure 1 below.
 - ① You can directly add devices and authorized users on the Power Station Creation Success page in Figure 1, or click the [Finish] button in the upper right corner to skip device binding and authorization first.
 - ② Later, you can also directly in the power station management list interface (Figure 2 below), click the power station name to enter the main interface of the power station editor (Figure 3) to complete and supplement the information.

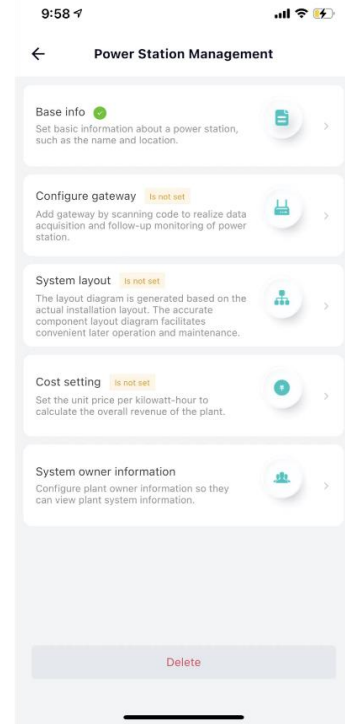
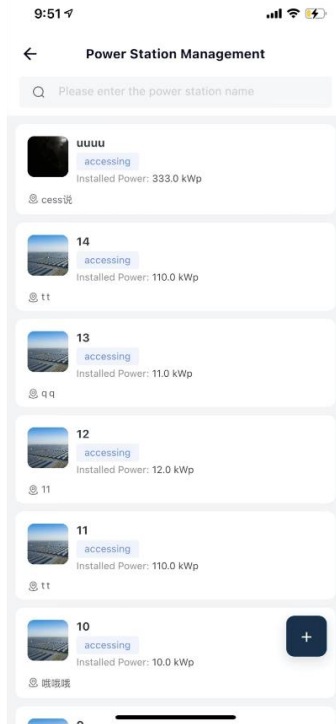
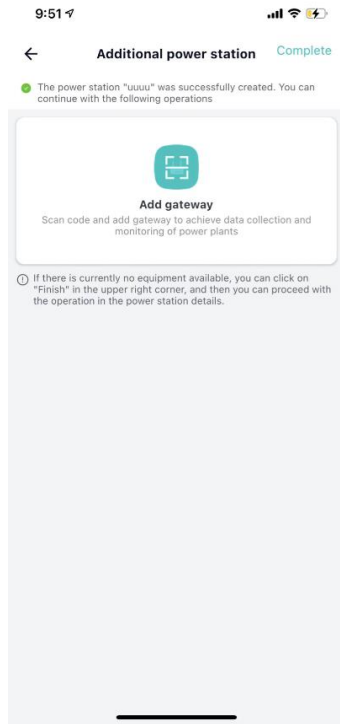

Step 3: Configure the gateway

■ Wired connection and 4G distribution network

- ① Turn on the camera permission of the mobile phone: Click "Add Gateway" on the successful completion page of the power station creation or click "Configure Gateway" on the main interface of the power station editing. The system will enter the scan code interface. When using it for the first time, the page prompts that you need to add the permission to "use the camera", which is convenient for you to scan the code recognition..

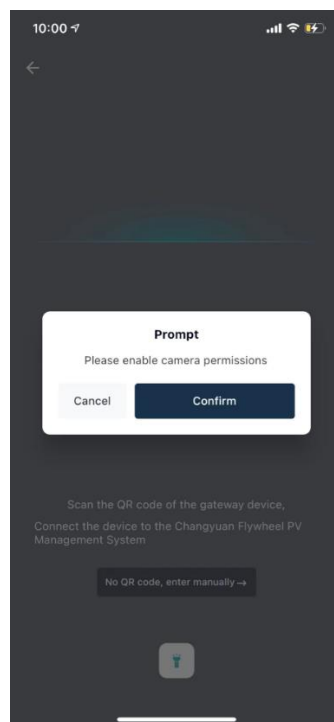

- ② Reset the device: connect the device to the power supply and connect it to the home router, and confirm that the indicator light is always on.

Indicator light	Flicker condition	Status
POWER (power lamp)	Always bright	Power supply is normal
	Constant extinction	Power supply abnormality
NET (Network Light)	Flash mob	Unable to connect to IOT server
	Always bright	Connect to the IOT server normally, and flash when you receive a message from the platform
	Slow flash	AP distribution network

- ③ After completing the authorization and confirming that the device is in the distribution network state, you can choose to directly scan the barcode or QR code on the device to add, or manually enter the serial number to add.

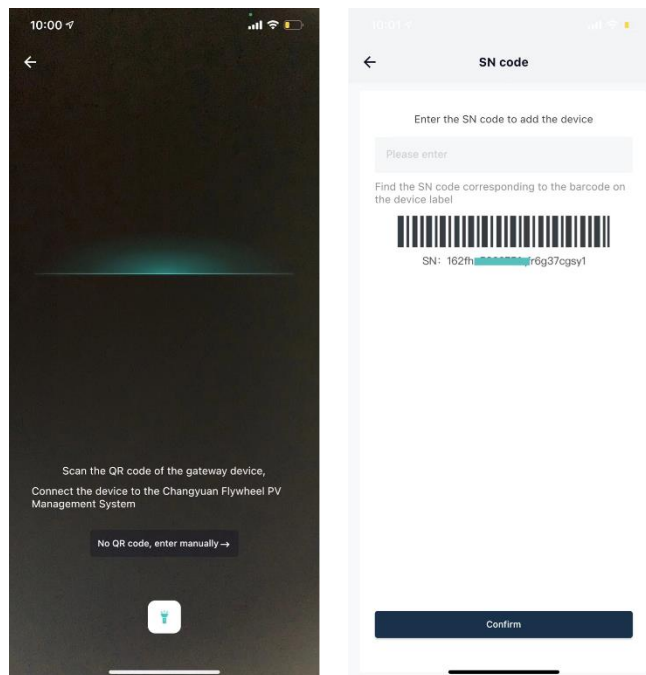

- ④ The device will enter the distribution network interface if the code is successfully scanned, and the distribution network will count down for 2 minutes.

If the addition is successful, the system will enter the distribution network success interface (Figure 2 below). You can set the device name in the current interface. After setting the name, click the [Finish] button to enter the main interface of the gateway.

If the gateway fails to be added, the system will enter the distribution network failure interface. Please check the device and network conditions. And the network distribution can be performed again after the device is reset.

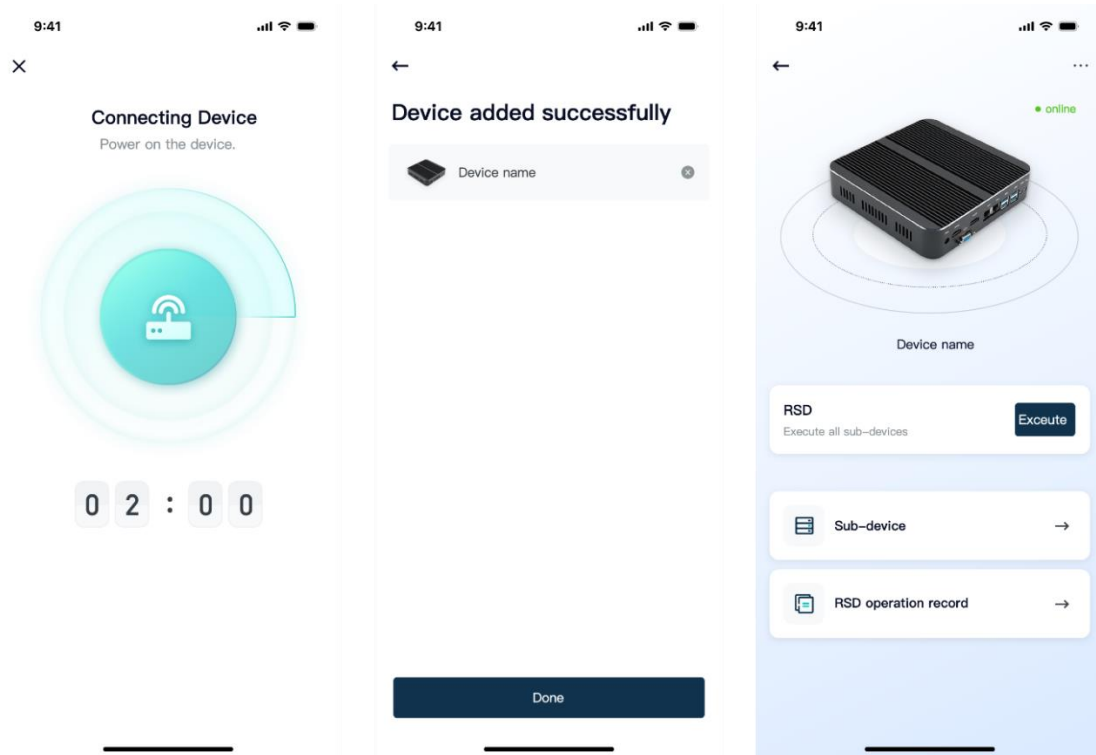

■ Wi-Fi mode

Please use 2.4G network for configuration in all the following network distribution processes. 5G network is not currently supported.

① Enter AP distribution network mode

Press and hold the Reset button for 3-10 seconds, and the gateway will enter the AP network distribution mode

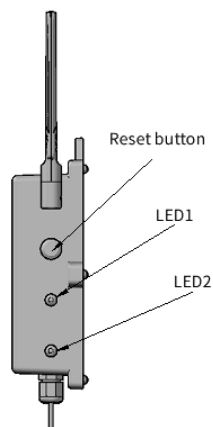

Click on the corresponding power station on the APP, enter the power station configuration equipment interface, select Add Collector, and scan or input the SN of the network gateway to be distributed. After finding the corresponding device, switch to the Wi-Fi distribution network as shown in the figure.

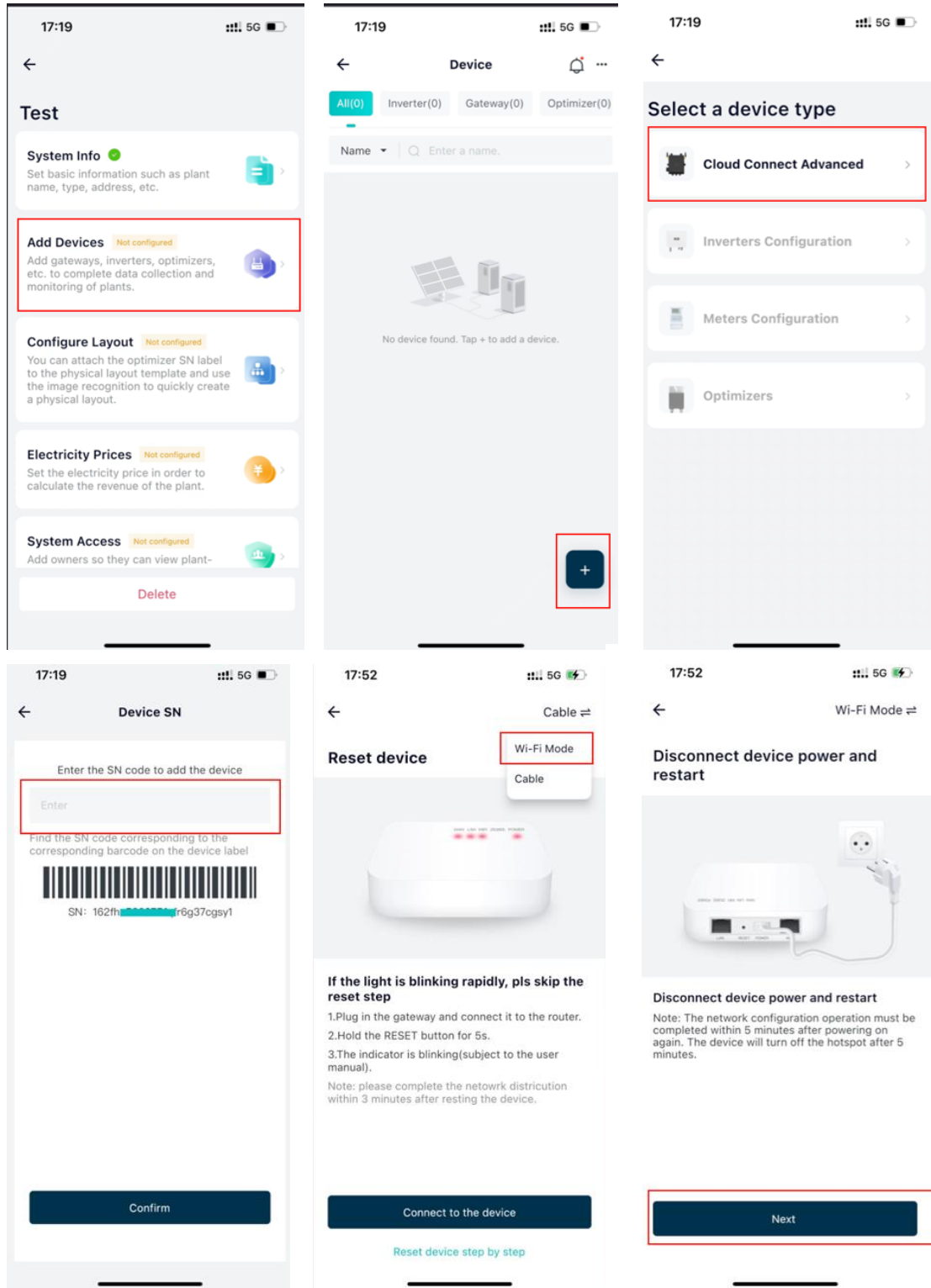

② Confirm Wi-Fi information

Please make sure your phone is connected to the Wi-Fi network at home, consistent with the network displayed on the page, and enter the connection password for that network. After completing the input and confirming that the information is correct, click the [Next] button.

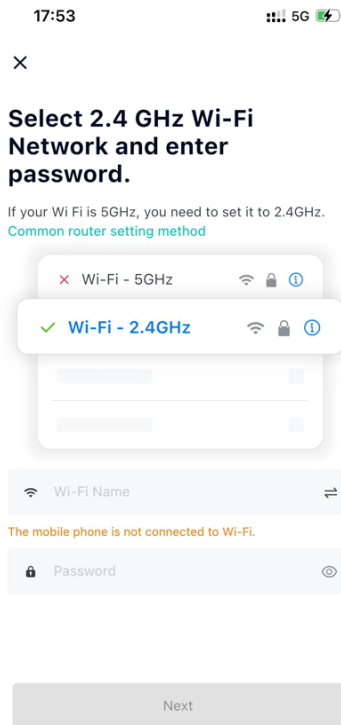

③ Connect to the gateway AP network

According to the instructions on the page, you now need to connect your phone to the network "SolarPilot_XXXXX". Please click the "Go to Connect" button and connect to this network in the "WLAN" page" of the phone system.

After successful connection, please return to the Flywheel Smart Photovoltaic APP application.

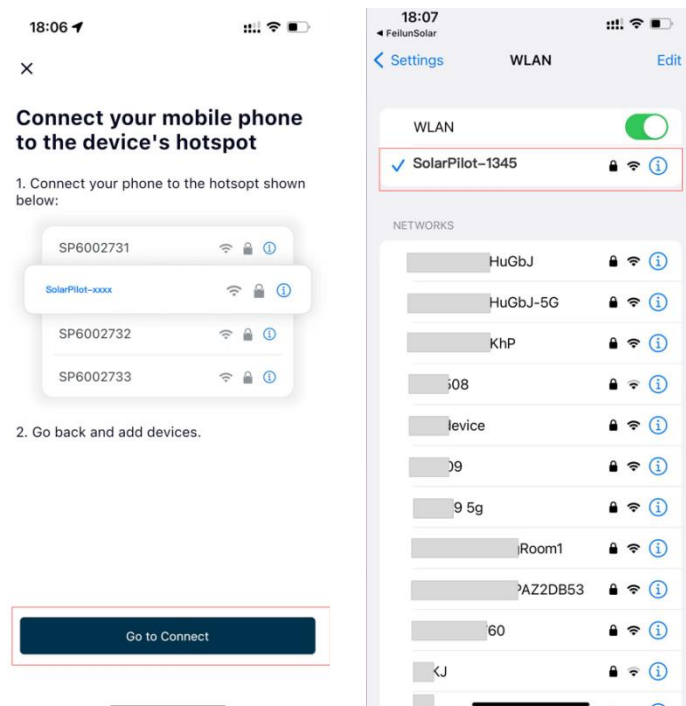

④ Wait for the configuration to complete

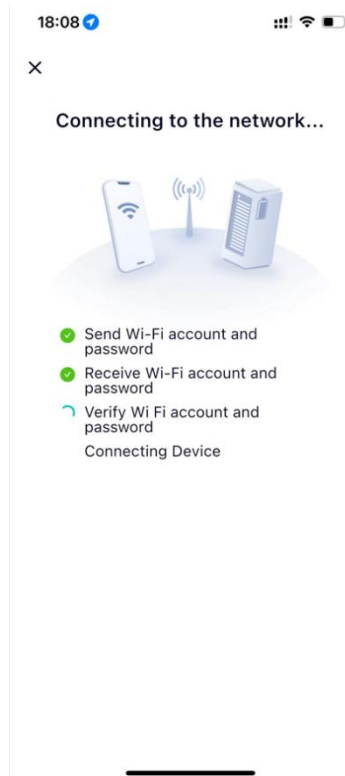

Note: If the page prompts that the configuration fails, please check and try again according to the following possible reasons.

- Make sure your phone's WLAN is turned on
- Confirm that the Wi-Fi network at home can access the Internet normally
- Ensure that the wireless router does not enable the black and white list
- Try to shorten the distance between your phone and device
- Try connecting to another Wi-Fi network to reconfigure the network
- Try removing special characters such as (, ; " = " " `) from the Wi-Fi network name

6.4 Add Layout

Select the gateway to which the optimizer needs to be configured, then select the template to shoot the QR code that has just been pasted, and follow the figure to complete the optimizer layout generation.

Note: An optimizer can have up to 30 gateways.

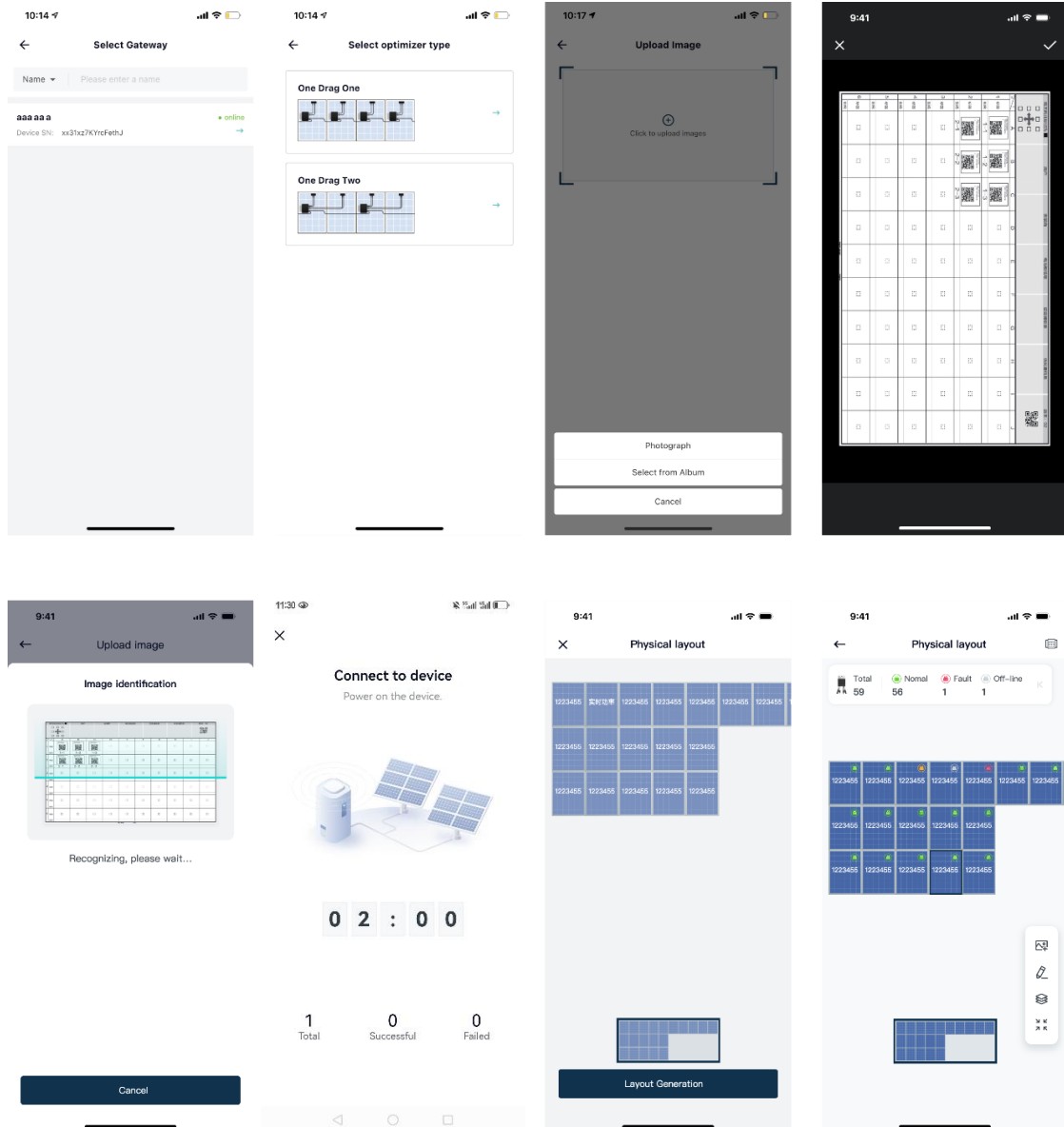

6.5 Improve the information

Enter the revenue per kilowatt hour, and the system will calculate the revenue of the entire power station according to the unit price set here.

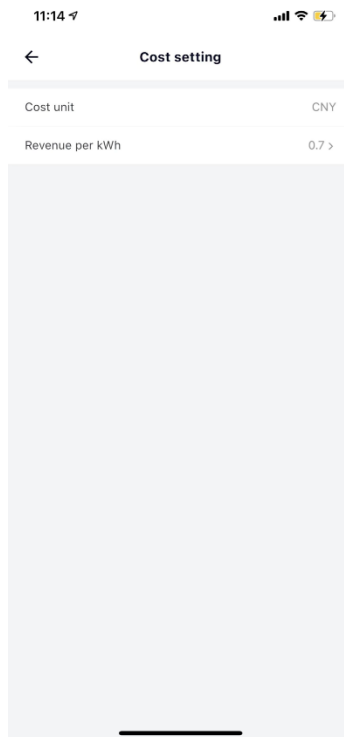

Enter the owner account number and user name to complete the authorization operation of the power station.

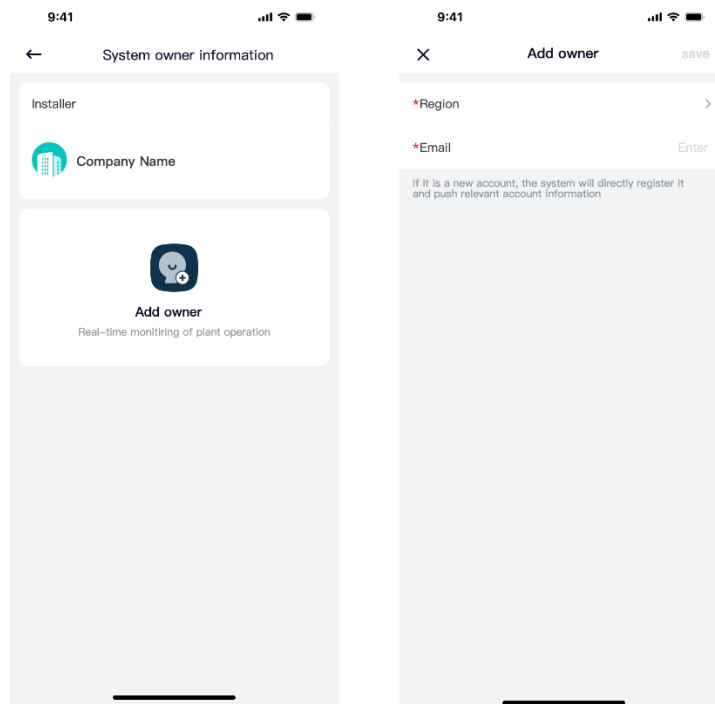

7 Replace the gateway

7.1 Prerequisite conditions

Please use special insulation tools, wear insulated shoes and protective gloves before operating.

Ready for the new gateway.

Prepare a phone with a monitoring app installed.

Ensure that both the optimizer and gateway are online.

7.2 Operation steps

- The normal gateway (replacement gateway) will need to be powered on ;
- Add a normal gateway to the corresponding power station using the APP ;
- Power off the abnormal gateway (replaced gateway)
- Operate the gateway replacement process on the app

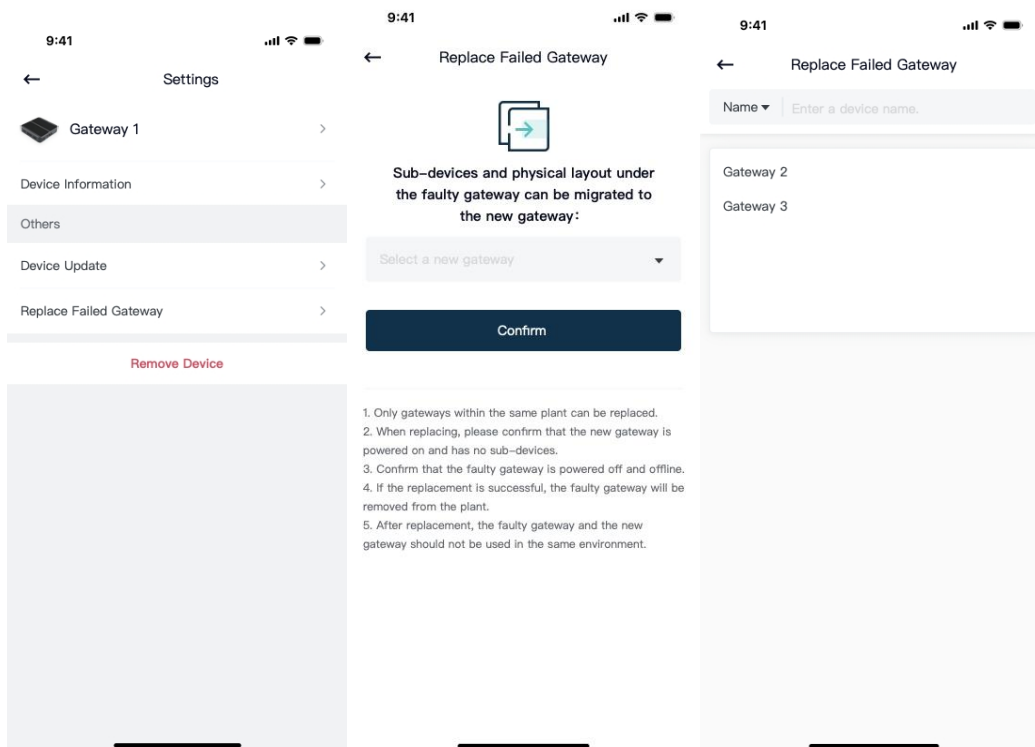



8 Technical indicators

Model	SP1-Zigbee-GW-W
Communicate with Optimizer	
Communication type	Zigbee wireless communication
Maximum distance	30m Indoor/100m Outdoor
Maximum number of devices	30 PCS
Communicate with RSD button	
Control mode	IO
Communicating with Cloud Computing Platforms	
Wired Internet access	RJ45×1 100Mbps
Wireless Internet access	Wifi 802.11b/g/n 2.4G
Number of antennas	2
Sampling interval	1 minute
Expand communication connections	
RS485	COM×1 , 9600bps, ModBus-RTU
interaction	
Reset button	Reset button×1
Indicator light	LED×2
APP	SolarPilot APP
General parameters	
Working temperature	-20°C ~ 55°C
Size	181mm*163mm*51mm (height * width * thickness)
Weight	≤450g
Installation method	Wall mount
Protection level	IP65
Power supply	DC 12V

Specification	
Meet the standards	CE、ROSH
Compatibility with Optimizer	
Model	SP1、SP2、SP3



If you have technical querise concerning our products,
please contact us:

Address: Arndtstrasse 27b, 22085 Hamburg, Germany

E-mail: info@solarpilot.com

Telephone: [+86 0751-88779861](tel:+86075188779861)

Website: <https://www.solarpilot.com>