

Smart PV Optimizer

SP1-600W-AL/SP1-600W-AS

User Manual

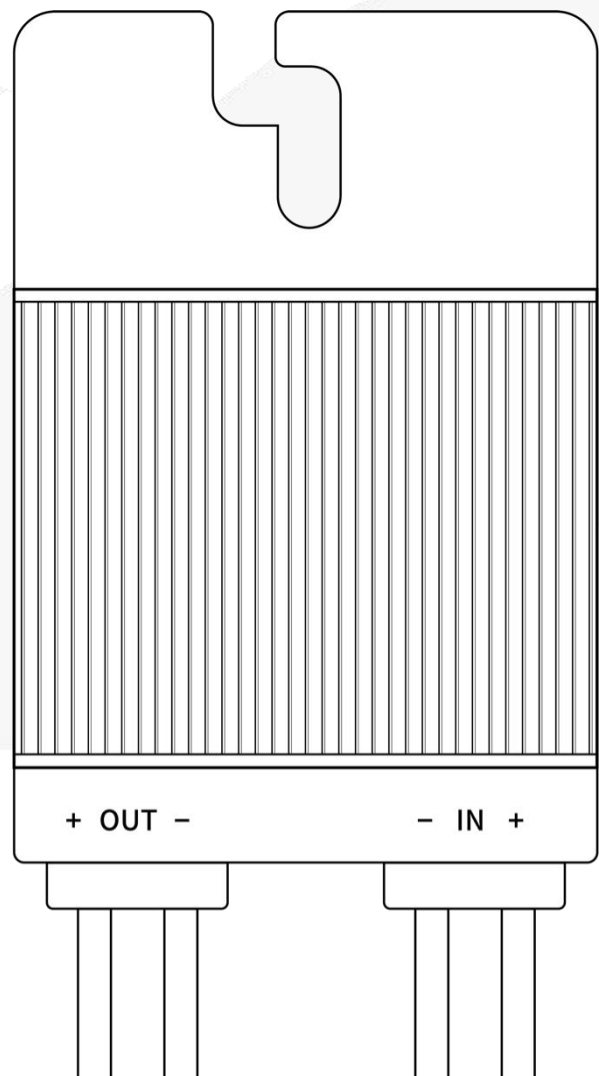

Copyright © SolarPilot Energy GmbH. 2023. All rights reserved.

No part of this document may be reproduced or transmitted in any form or by any means without prior written consent of SolarPilot Energy GmbH.

Important Notice

The purchased products, services and features are stipulated by the contract made between SolarPilot Energy GmbH and the customer. All or part of the products, services and features described in this document may not be within the purchase scope or the usage scope. Unless otherwise specified the contract, all statements, information, and recommendations in this document are provided "AS IS" without warranties, guarantees or representations of any kind, either express or implied.

The material furnished in this document is believed to be accurate and reliable. However, SolarPilot assumes no responsibility for the use of this material. SolarPilot reserves the right to make changes to the material at any time and without notice. You may refer to the SolarPilot website (www.solarpilot.com) for the most updated version.

Trademarks and Permissions

The SolarPilot logo, consisting of the word "SolarPilot" in green with a stylized "P" and "i".

and the SP trademarks used in this manual is owned by SolarPilot Energy GmbH.

All other trademarks or registered trademarks mentioned in this manual are the property of their respective owners.

Software Licensing

It is prohibited to use some or all of the data in the firmware or software developed by the company for commercial purposes in any way.

It is forbidden to reverse compile, decrypt or otherwise destroy the original program design of the software developed by the company.

SolarPilot Energy GmbH

Address: Arndtstrasse 27b, 22085 Hamburg, Germany

E-mail: info@solarpilot.com

Website: <https://www.solarpilot.com>

V1.02 (2/Jan/2025)

About this manual

This document mainly introduces the functional characteristics, electrical parameters, product structure and so on of smart photovoltaic power optimizer for purpose of overview, installation, commissioning, maintenance, and troubleshooting. The pictures in this article are for reference only, and the specifics are subject to the actual product. Please read the manual carefully before using the product and keep it in a convenient place.

The content of the manual will be constantly updated and revised, but it is inevitable that there will be slight discrepancies or errors with the actual product.

Users should refer to the purchased product, and can download the latest version of the manual through www.solarpilot.com or sales channels.

Scope of application

This manual is mainly aimed at the following products:

Smart PV Power Optimizer (SP1-600W-AS/SP1-600W-AL)





Hereinafter, unless otherwise noted, are referred to as "optimizer".

Intended Readers

- Sales engineer
- Technical support engineer
- Hardware installation engineer
- Maintenance engineer

Symbolic conventions

In order to ensure the personal and property safety of users when using the product, and to use the product more efficiently and optimally, the relevant information is provided in the manual, and the following symbols are used to highlight it. The following lists the symbols that may be used in this manual, please read them carefully to make better use of this manual.

Symbol	Description
	Indicates a high potential hazard that, if not avoided, would result in death or serious injury.
	Indicates a moderate potential hazard that, if not avoided, would result in death or serious injury.
	Indicates a low potential hazard that, if not avoided, would result in moderate or light injury.
	Indicates a potentially hazardous situation which, if not avoided, could result in equipment damage, data loss, performance deterioration, or unanticipated results. NOTICE is used to address practices not related to personal injury

 **NOTE**

Supplements the important information in the main text. NOTE is used to address information not related to personal injury, equipment damage, and environment deterioration.



Directory

1 SAFETY INSTRUCTIONS	1
1.1 General Security Precautions	1
1.2 Statement	1
1.3 Personnel Requirements	2
1.4 Mark Protection	2
1.5 System Installation	2
1.6 Electrical Connections	3
1.7 Operation	3
1.8 Maintenance and Replacement	3
2 PRODUCT DESCRIPTION	4
2.1 Applicable Systems	4
2.2 Product Introduction	6
2.3 System Topology	8
3 UNPACKING AND STORAGE	11
3.1 Unpacking and Inspection	11
3.2 Identify the optimizer	11
3.3 Scope of Supply	13
3.4 Optimizer storage	13
4 INSTALLATION STEPS	14
4.1 Requirements and Precautions	15
4.2 Installation Method	16
4.3 Measure Optimizer Voltage	18
4.4 Measure string voltage	19
4.5 Connect to the inverter	21
4.6 Generate Layout	21

5 APP OPERATION GUIDE	23
5.1 Download the APP	23
5.2 Registration and Login	23
5.3 Create a Power Station	24
5.4 Add Layout	31
5.5 Improve the information	33
6 PRACTICE RUNNING	34
6.1 Practice Running Steps	34
6.2 Execute Recover Output(Very Important)	34
7 TROUBLESHOOTING	35
8 REPLACE THE OPTIMIZER	36
9 TECHNICAL PARAMETERS	37

1 Safety Instructions

As a power electronic device, the optimizer must comply with relevant safety regulations during its installation, practice running, operation and maintenance. Unreasonable use or misoperation may lead to:

- Harm the life and personal safety of the operator or a third party.
- Damage to the optimizer or other property belonging to the operator or a third party.

Precautions during operation will be explained in detail in the corresponding section.



The safety precautions in this manual cannot contain all the specifications that should be followed, and various tasks should be carried out in combination with the actual situation on site.

SolarPilot does not accept any responsibility for any loss caused by not following the safety precautions in the manual.

1.1 General Security Precautions

- When carrying out various operations of this product, the relevant equipment precautions and special safety instructions provided by SolarPilot Energy GmbH must be strictly followed. Personnel responsible for installing and maintaining SolarPilot Energy GmbH equipment must first undergo strict training, understand various safety precautions, and master correct operation methods before installing, operating and maintaining the equipment. SolarPilot Energy GmbH does not assume any responsibility for violations of general safe operating requirements and safety standards for the use of equipment.
- Before starting the operation, please read the precautions and operation instructions in this manual carefully to avoid accidents. The "dangers", "warnings", "instructions" and "precautions" in each manual do not represent all the safety matters that should be observed, but only supplement the safety precautions in various operations.
- Operators are expected to comply with local regulations and codes. The safety precautions in the manual are only in addition to local safety codes.
- It is strictly forbidden to wear watches, bracelets, rings and other easily conductive objects during operation.
- Special insulated tools must be used during operation.
- Torque wrenches should be used to fix the bolts and double-checked with red and blue markings. After the installer confirms that the bolts are tightened, paint the blue logo on the bolts; after the inspector confirms that the bolts are tightened, paint the red logo. If the bolts or bolts of the fixed equipment are not installed according to the torque requirements, there is a risk that the equipment will come loose from the installation.
- Installation or maintenance operations must conform to the sequence of steps of the task, and do not change the structure and installation sequence of the equipment without the manufacturer's permission.
- Installation must be carried out in strict accordance with the requirements of the Quick Guide.

1.2 Statement

In the event of any of the following circumstances, SolarPilot Energy GmbH has the right not to carry out quality assurance.

- Damage in transit.
- Damage caused by storage conditions not meeting product doc requirements.
- Incorrect installation and use of product.
- Unqualified personnel to install and use product.
- Failure to follow the operating instructions and safety warnings in the product and doc.
- Operate in harsh environments beyond product and doc specifications.
- Operate beyond the parameters specified in the applicable technical specifications.
- Unauthorized disassembly, modification of products, or modification of software code.
- Damage caused by abnormal natural environment. (Force majeure, such as lightning, fire, storm, etc.)
- Exceeded the quality assurance period and did not extend the quality assurance service.
- Any installation and operating environment beyond those specified in the relevant international standards.

1.3 Personnel Requirements

Optimizer installation, electrical connection, maintenance, troubleshooting, and replacement operations must be performed by professional electrical technicians.

- Operators need to undergo professional training.
- Operators should read this manual completely and master the safety matters related to operation.
- Operators should be familiar with the relevant safety regulations of electrical systems.
- Operators need to be fully familiar with the composition and working principle of the entire photovoltaic grid-connected power generation system, as well as the relevant standards of the country/region where the project is located.
- Operators must wear personal protective equipment.

1.4 Mark Protection

- The warning label on the optimizer contains important information for its safe operation, and human alteration and damage are strictly prohibited.
- There is a nameplate on the back of the optimizer, which contains important parameter information related to the product, and artificial alteration and damage are strictly prohibited.

1.5 System Installation

- The optimizer is prohibited from being installed in locations where water can submerge for a long time.
- Improper operation during the installation and operation of the optimizer may lead to fire, and the storage of flammable and explosive materials is prohibited in the installation location area.
- It is forbidden to cut the cable that comes with the optimizer, otherwise the quality assurance will fail.
- When installing the optimizer, make sure that it is not electrically connected and energized.
- A certain distance should be reserved between the optimizer and the surrounding objects to ensure sufficient installation and heat dissipation space.

1.6 Electrical Connections



Before making electrical connections, make sure that the optimizer is not damaged, otherwise it may cause electric shock or fire.

- All electrical connections must meet the electrical standards of the country in which they are located.
- The cables used in the photovoltaic grid-connected power generation system must be firmly connected, well insulated, and of suitable specifications.
- The optimizer output terminal does not support hot swapping, otherwise, it may cause damage to the optimizer.
- The DC connector model of the optimizer is Staubli MC4, make sure the mating DC connector model is the same. If the model is different, the DC connector manufacturer must provide a connector compatibility report and a third-party external laboratory (TUV, VED or Bureau Veritas) report. Using other incompatible DC connectors may have serious consequences, and equipment damage caused by them is not covered by the equipment quality assurance.

1.7 Operation



During the operation of the optimizer in the string, there is a high voltage, which may produce electric shock, resulting in death, serious personal injury, or serious property damage. Please strictly follow the safety precautions listed in this manual and other related documents.

- When the optimizer is running, the temperature is high and there is a risk of burns. Do not touch it.
- Local regulations and codes should be observed when operating equipment.

1.8 Maintenance and Replacement



During the operation of the optimizer, there is a high voltage, which may produce electric shock, resulting in death, serious personal injury, or serious property damage. Therefore, before any maintenance work, the optimizer must be powered off and operated strictly in accordance with the safety precautions listed in this manual and other related documents.

- Maintain the optimizer with a good understanding of this manual and with appropriate tools and test equipment.
- During the maintenance process, please try to avoid unrelated personnel entering the maintenance site, and temporary warning signs or fences must be erected for isolation.
- The fault must be dealt with before the optimizer can be powered on again, otherwise it may cause the fault to expand or damage the equipment.
- During maintenance, please follow the electrostatic protection regulations and wear anti-static gloves.
- If the equipment fails, please contact your dealer or the original factory.

2 Product Description

2.1 Applicable Systems

SP1-600W-AS/SP1-600W-AL defines the first generation of smart PV optimizer product. The photovoltaic power optimizer is a DC/DC conversion power supply used behind the photovoltaic modules in the photovoltaic system. It increases the power generation of photovoltaic systems by continuously tracking the maximum power point (MPP) of each photovoltaic module. The power generation of the system is connected to the inverter in the latter stage. The inverter converts the direct current generated by the photovoltaic cells into alternating current that meets the grid requirements and feeds it into the grid. The optimizer can be applied to the following scenarios:

(1) Grid-connected PV system;(2) Off-grid PV and ESS system;(3)Grid-connected PV and ESS system.

CAUTION

- The optimizer cannot be connected to photovoltaic strings that require positive or negative ground.
- During the installation and operation of the optimizer, please ensure that the positive or negative poles of the photovoltaic string are not short-circuited to ground, otherwise, it may cause a DC short circuit of the optimizer, resulting in equipment damage, which will not be within the scope of quality assurance.
- Before the optimizer is installed, confirm that the module parameters meet the requirements of the optimizer.

1) Grid-connected PV system

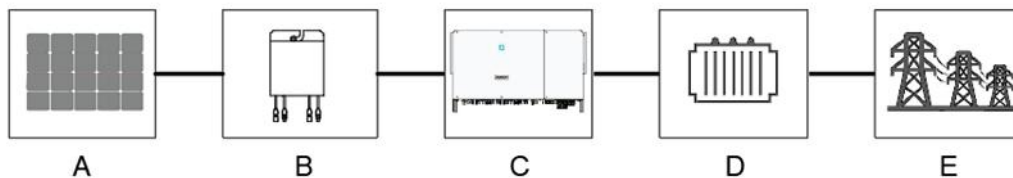

Section	Description	Remarks
A	PV modules	Monocrystalline silicon, polycrystalline silicon, thin film battery without grounding
B	Optimizer	SP1-600W-AS/ SP1-600W-AL
C	Inverter	String inverter, centralized inverter, distributed inverter
D	Step-up transformer	Raise the output voltage of the inverter to a level that meets the requirements of the grid
E	Power grid	Power Grid supported by Inverters

2) Off-grid PV and ESS system

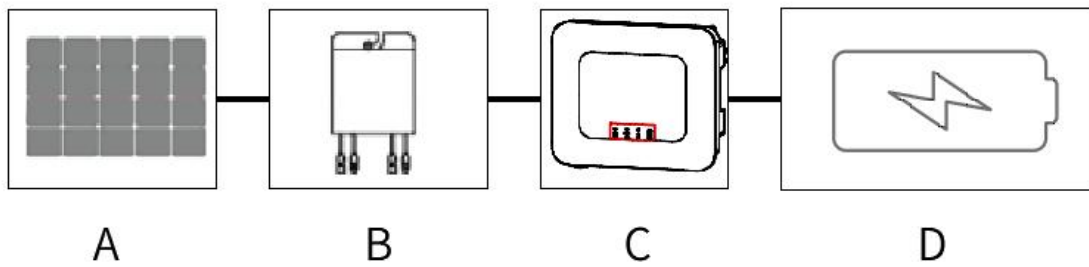

Section	Description	Remarks
A	PV modules	Monocrystalline silicon, polycrystalline silicon, thin film battery without grounding
B	Optimizer	SP1-600W-AS/ SP1-600W-AL
C	Off-grid inverter	Off-grid inverter
D	Battery	Lead-acid battery, lithium battery

3) Grid-connected PV and ESS system

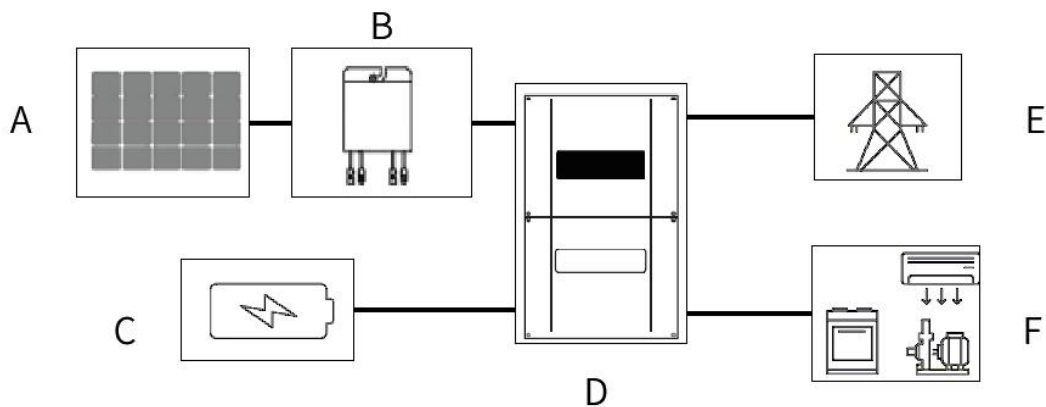

Section	Description	Remarks
A	PV modules	Monocrystalline silicon, polycrystalline silicon, thin film battery without grounding
B	Optimizer	SP1-600W-AS/ SP1-600W-AL
C	Battery	Lead-acid battery, lithium battery
D	All-in-One inverter	All-in-One inverter
E	Power grid	Power Grid
F	Load	DC or AC load

2.2 Product Introduction

The photovoltaic power optimizer is a DC/DC conversion power supply for the post-stage of photovoltaic modules in photovoltaic systems. It increases the power generation of photovoltaic systems by continuously tracking the maximum power point (MPP) of each photovoltaic module. It also has module-level shutdown, module-level monitoring and other functions.

2.2.1 Functional Features

- **Module-level MPPT function:** Increases the power generation of the photovoltaic system by continuously tracking the maximum power point of the photovoltaic module.
- **Module-level shutdown function:** Realize module-level voltage shutdown, fire emergency stop button start or background control shutdown, the optimizer can adjust the module output voltage to a safe range.
- **Module-level monitoring function:** The optimizer can detect the running status of modules and achieve module-level monitoring.

2.2.2 Model Description

The description is as follows:

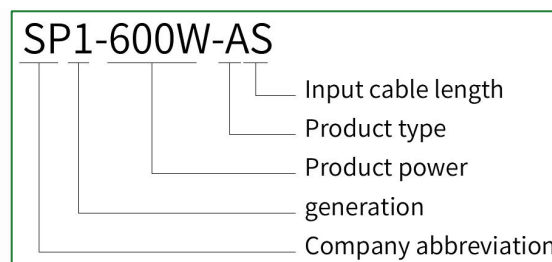

Optimizer model	Rated input power	Input line length	Output line length
SP1-600W-AS	600W	120mm/120mm	1200mm/1200mm
SP1-600W-AL	600W	1000mm/1000mm	1200mm/1200mm

2.2.3 Product interface

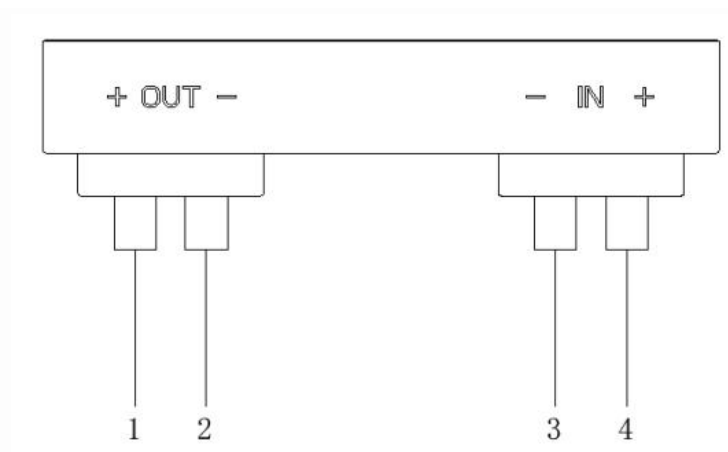
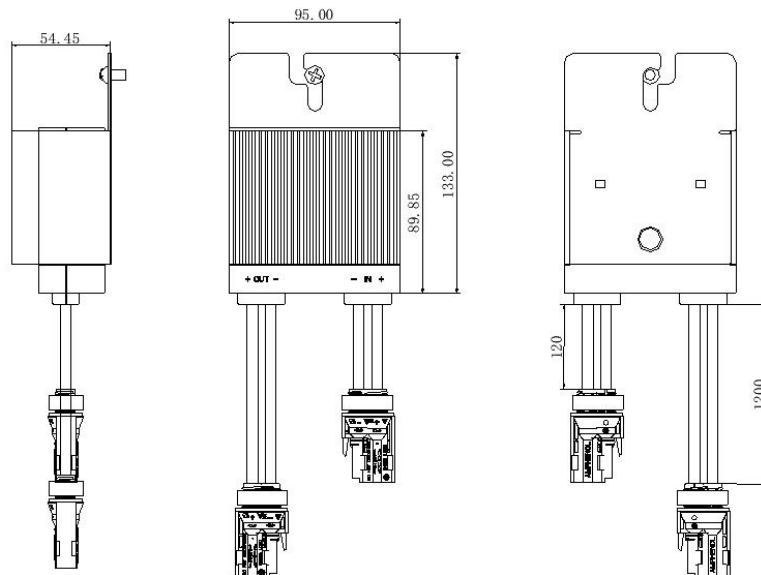

Figure 2.2-1 Schematic diagram of the optimizer interface

Number	Name	Description
1	VOUT+	Connect to the positive pole of the inverter, or the VOUT- of the series optimizer, 1.2m
2	VOUT-	Connect to the negative pole of the inverter, or the VOUT+ of the series optimizer, 1.2m
3	VIN-	Connect to the negative pole of the photovoltaic module, 0.12m(AS)/1.0m(AL)
4	VIN+	Connect to the positive pole of the photovoltaic module, 0.12m(AS)/1.0m(AL)

2.2.4 Product Size

SP1-600W-AS:



SP1-600W-AL:

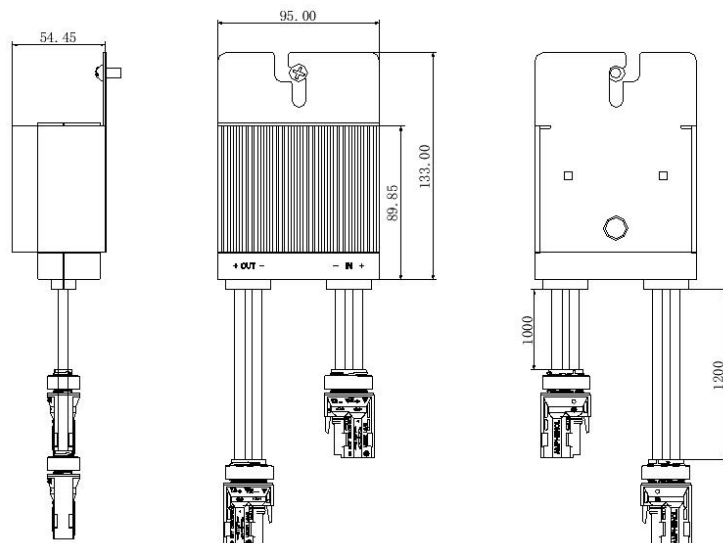

2.3 System Topology

2.3.1 Typical topology

In order to achieve component-level monitoring, the FL1 series optimizer needs to be used with a Zigbee gateway. The typical topology is shown below.

In the gateway topology, the RSD button and RS485 can be left unconnected if not needed.

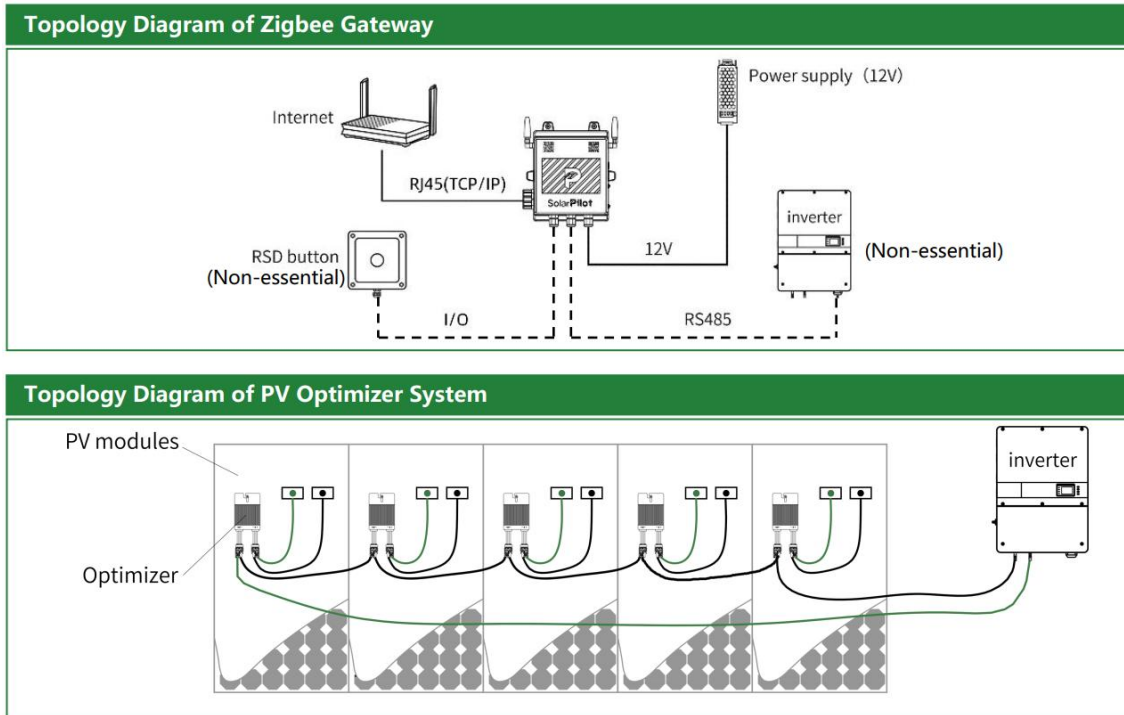

2.3.2 Other topology

In practical applications, the following simplified typologies may exist:

- Optimizer + Gateway + RSD Button: It can realize module-level MPPT, module-level operation and maintenance monitoring, and local/remote RSD control.
- Optimizer + Gateway: It can realize module-level MPPT, module-level operation and maintenance monitoring, and remote RSD control.
- Optimizer: It can realize module-level MPPT (the optimizer defaults to RSD state, you need to contact the manufacturer to recover the output).

2.3.3 Configuration Principles

When installing PV optimizers for different types of inverters, the number of optimizers supported by the string, the upper limit of the string power, and the parallel requirements for the strings are different. The principles of PV Optimizer configuration are as follows:

NOTE

- If only one string is connected to one MPPT, all of the modules in the string need to be installed with PV optimizers;
- If multiple strings are connected in parallel under one MPPT, the number and model of modules in different strings must be exactly the same, and all modules need to be installed with PV optimizers.

Examples of correct configuration:

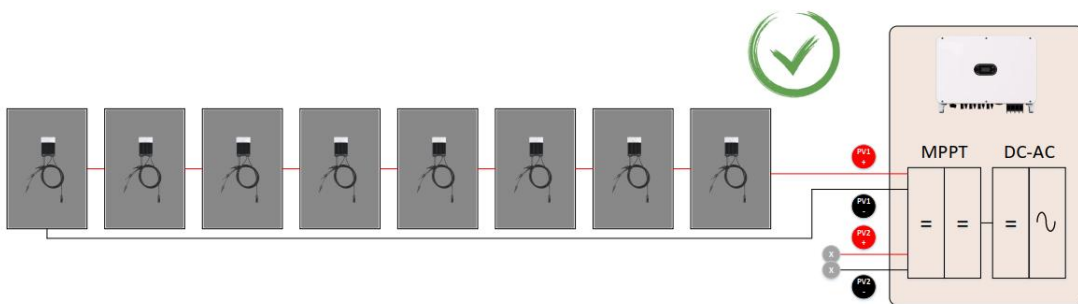
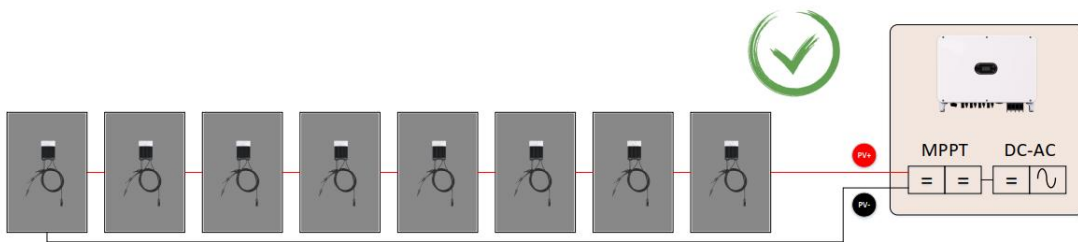

One MPPT connects one string

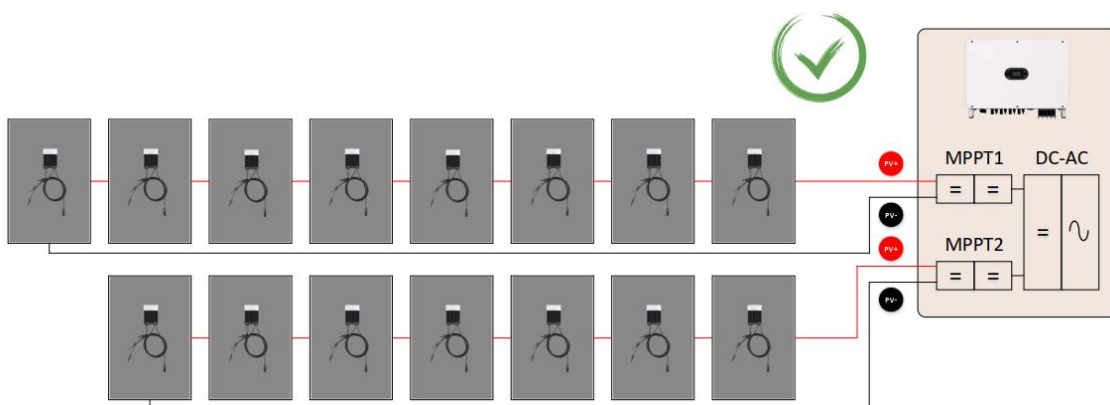

The MPPTs are isolated from each other and the optimizers can be installed separately

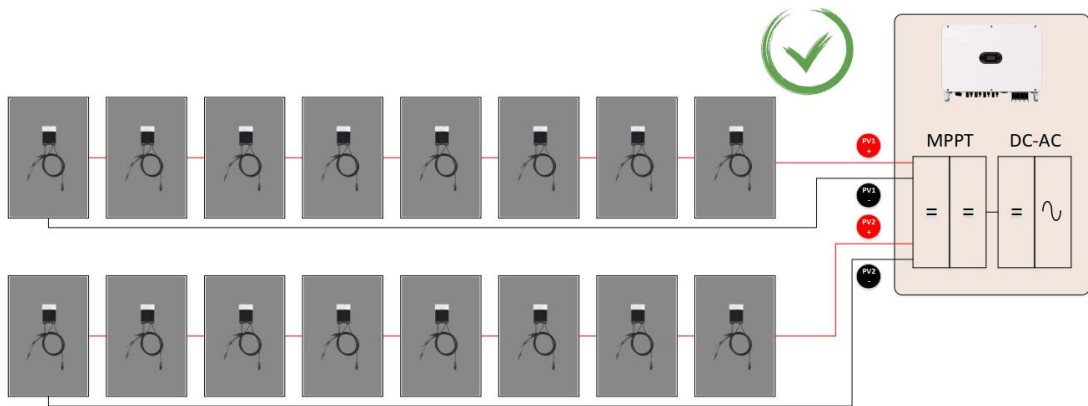

One MPPT supports multiple strings. The number and model of modules in the string must be exactly the same, and all of them must be installed with optimizers

Examples of incorrect configuration:

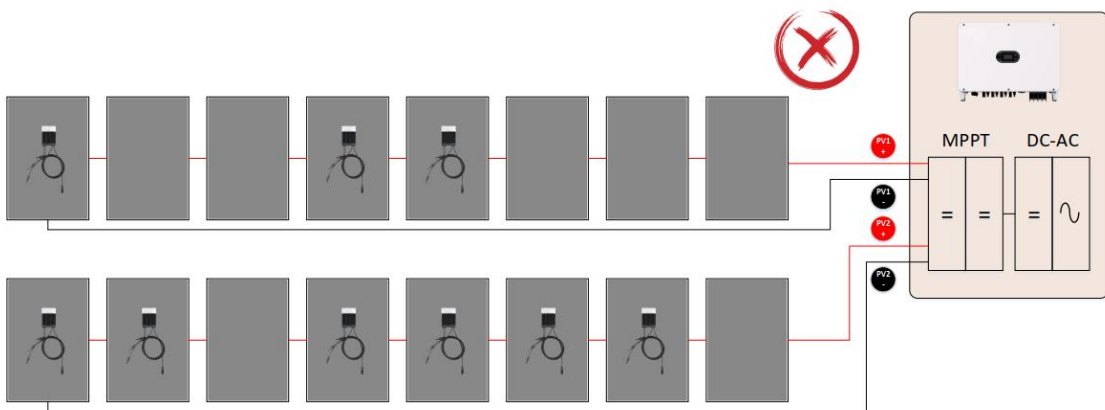

One MPPT supports multiple strings which do not support installing optimizers on some modules

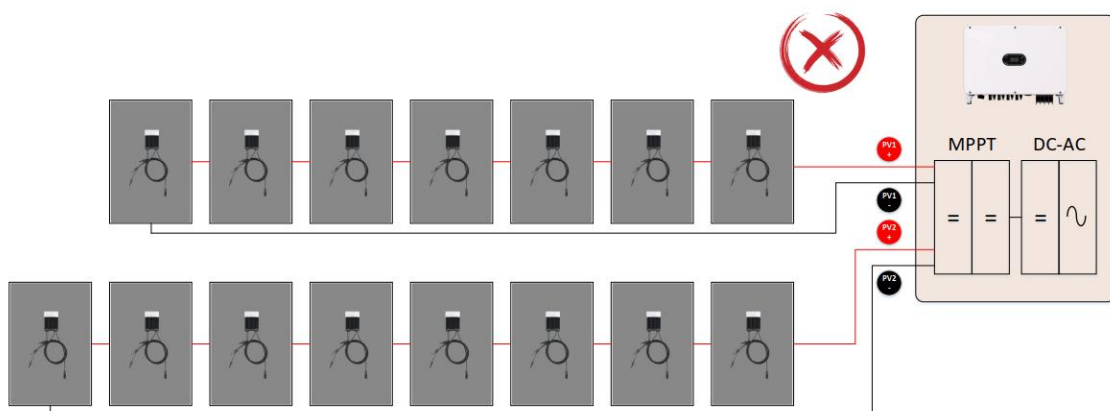

One MPPT supports multiple strings which do not support inconsistent number of modules

3 Unpacking and Storage

3.1 Unpacking and Inspection

The optimizer has been fully tested and strictly inspected before leaving the factory, but damage may still occur during transportation. Please conduct a detailed inspection before signing for the product.

- Inspect the packing box for damage.
- Check whether the goods are complete and in accordance with the order according to the packing list.
- Unpack and check whether the internal equipment is intact.

If any damage is found, please contact the transportation company or directly with SolarPilot Energy GmbH Company, and provide photos of the damage to facilitate service. Do not discard the original packaging of the optimizer. It is best to store the optimizer in the original packaging box after it is out of service and dismantled.

3.2 Identify the optimizer



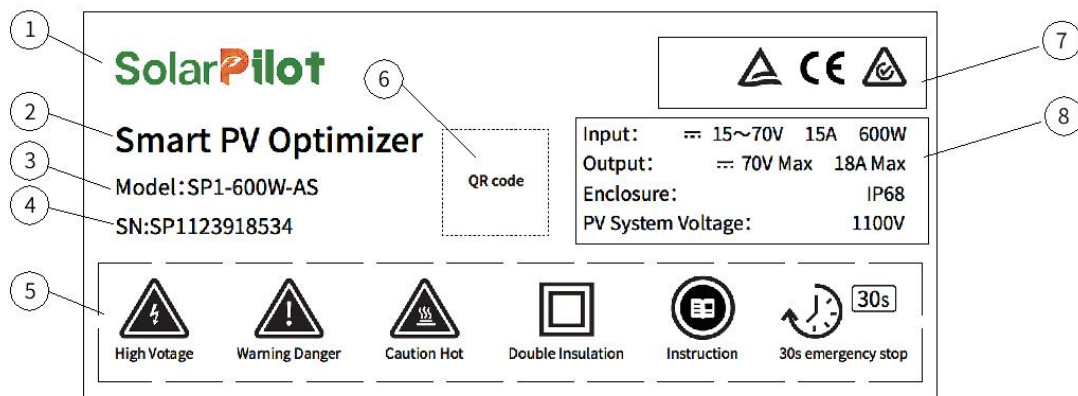



There is a nameplate attached to the back of the optimizer. The nameplate provides the model information of the optimizer as well as the most important parameters and certification marks.





Number	Description
1	SolarPilot Trademark
2	Optimizer Product Name
3	Optimizer Model Specifications
4	Optimizer SN Code
5	Related Symbols
6	Product SN QR code
7	Related Certification

8	Related Parameters
---	--------------------

Description of Nameplate Symbol Identification

 High Voltage	High Voltage warning
 Warning Danger	Warning Danger
 Caution Hot	High temperature warning
 Double Insulation	Double insulated marking
 Instruction	Read instruction manual
 30s emergency stop	30 seconds quick break

Certification Instructions

	Compliant with TUV certification mark
	Compliant with CE certification mark
	Compliant with RCM certification mark

3.3 Scope of Supply

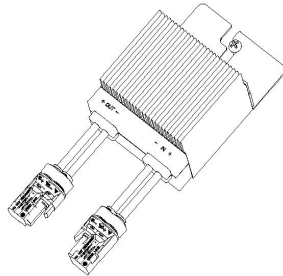

Optimizer

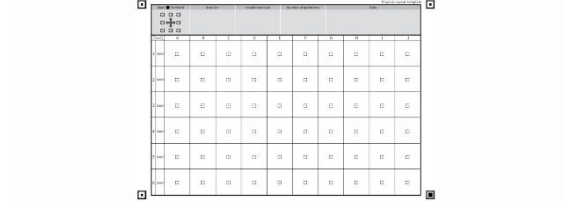

Layout Card

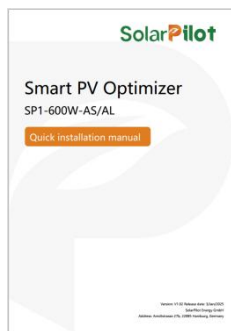

Quick installation manual



Certificate

3.4 Optimizer storage

If you do not use the optimizer immediately, you need to store it in a specific environment.

- Repack using the original packaging box, retaining the desiccant.
- Storage temperature range -40 °C-70 °C, relative humidity range 0-95%, no condensation.
- The storage time of the optimizer is more than half a year, and it needs to be fully checked and tested by professionals before it can be put into operation.

4 Installation steps

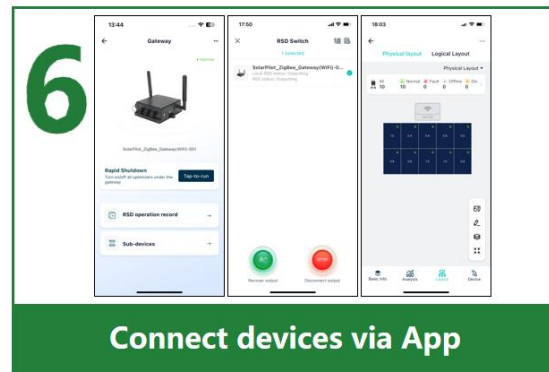
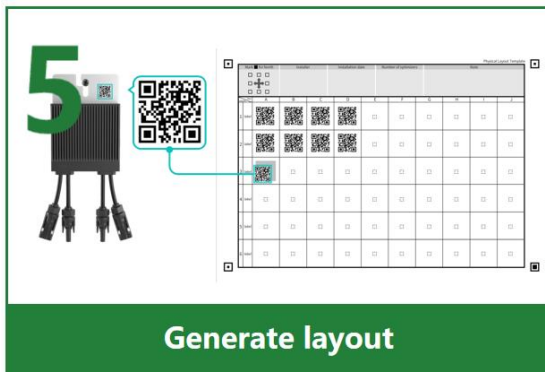
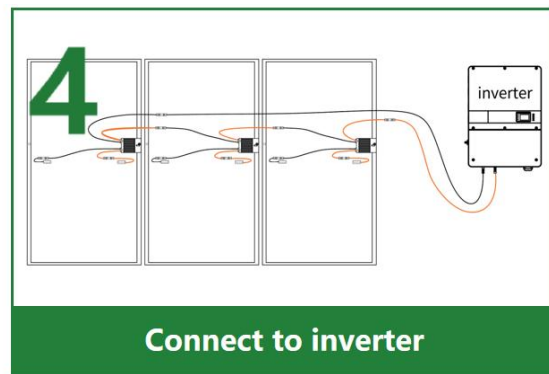
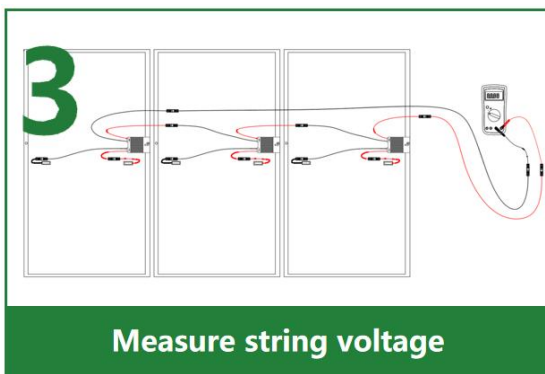
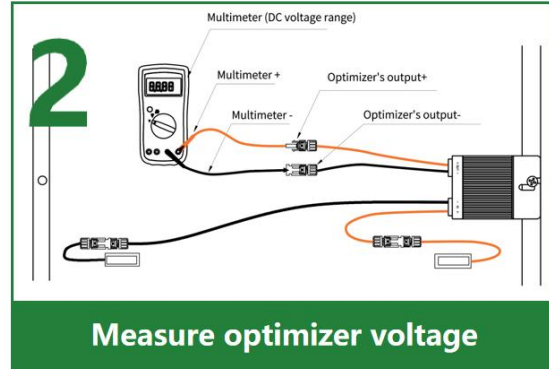

4.1 Requirements and Precautions



Before installing the optimizer, make sure there are no electrical connections



- Improper handling of equipment may result in minor injuries or contusions
- The position of the heat sink of the equipment must be kept uncovered, otherwise the heat dissipation of the optimizer will be affected and the good operation of the system will be affected









The optimizer installation requirements are as follows:

- The optimizer needs to reserve enough heat dissipation space, otherwise it may cause the optimizer to malfunction due to high temperature.
- The optimizer is prohibited from being immersed in water, otherwise it may cause the optimizer to be damaged.
- It is prohibited to damage the optimizer's own cables, otherwise the equipment damage caused by this is not covered by the warranty.
- Avoid exposing the optimizer to sunlight, otherwise it may cause the optimizer to malfunction due to high temperature.

<p>1. Reserve enough space for heat dissipation</p>	<p>2. Do not install in places that may be flooded</p>
<p>3. Do not damage original cables</p>	<p>4. Do not expose to the sun</p>

4.2 Installation Method

4.2.1 Installation Tools

		
Insulated shoes	Insulated gloves	Safety glasses
		
Wire stripper	M6/M8 sleeve	Pliers
		
MC4 wrench	MC4 pliers	Multimeter

4.2.2 Fixed on PV panel frame

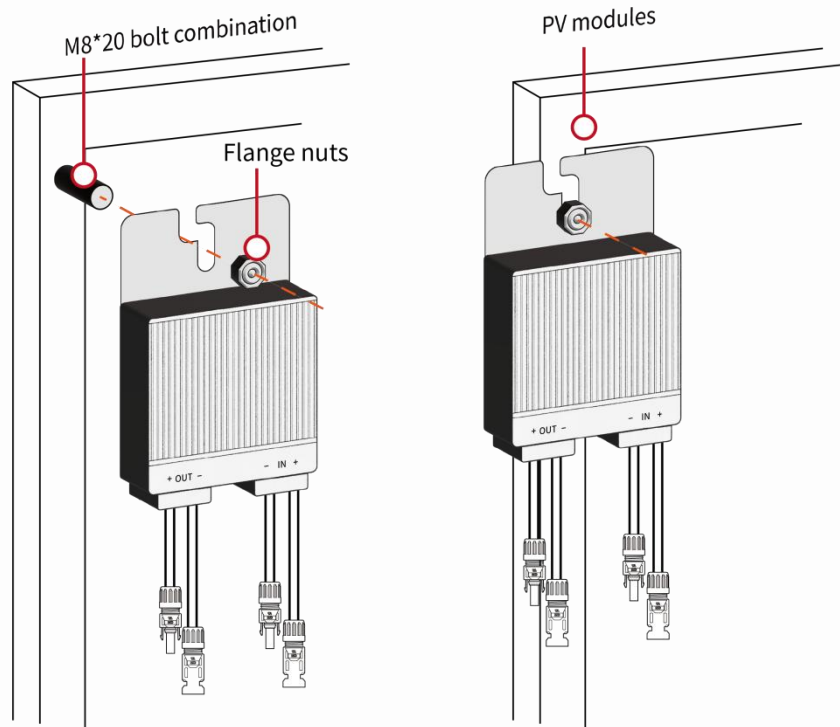

4.2.3 Fixed on bracket

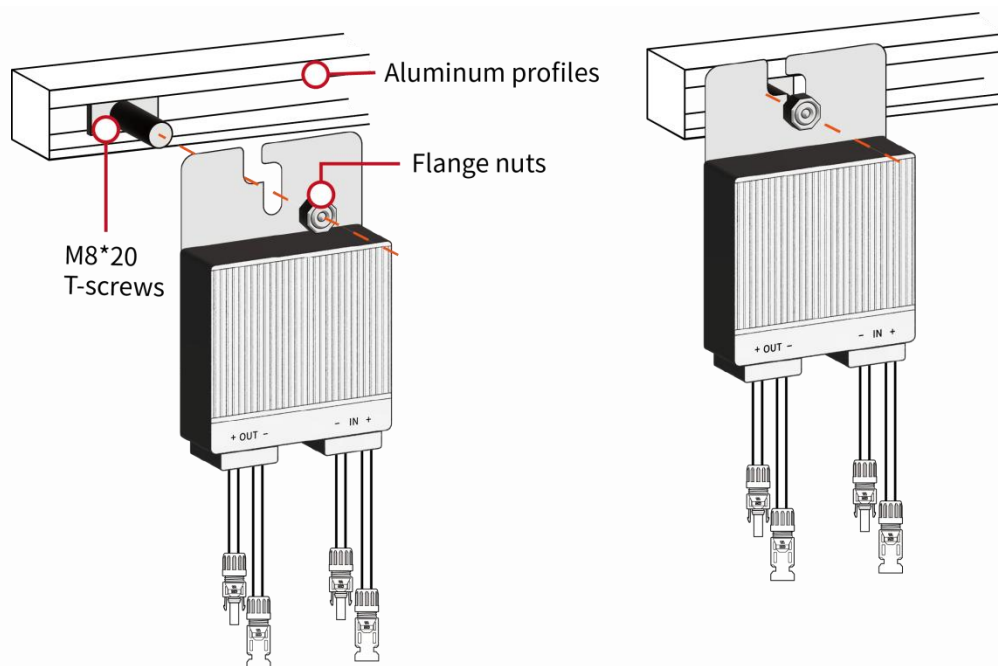

4.3 Measure Optimizer Voltage

4.3.1 Connected with PV modules

Connect the input positive electrode of the optimizer to the positive electrode of the module, and connect the input negative electrode of the optimizer to the negative electrode of the module.

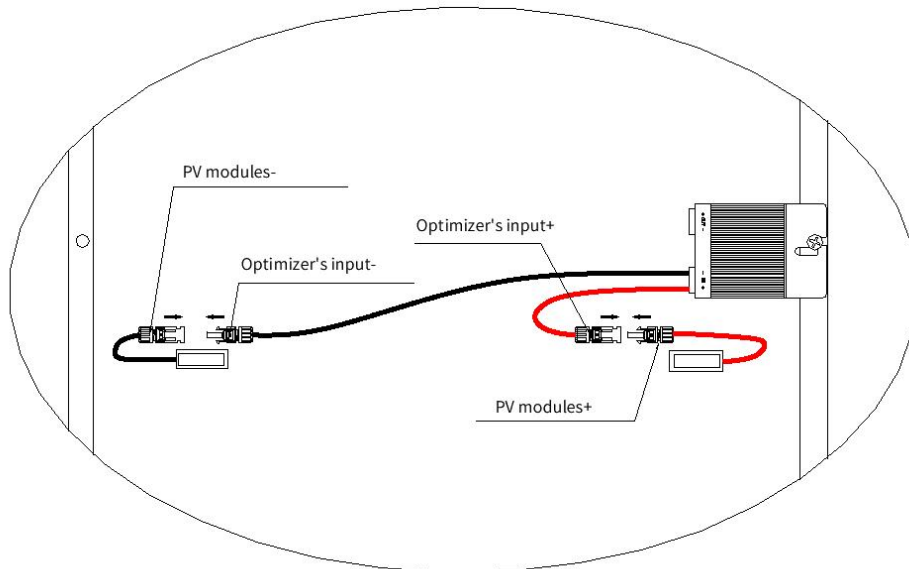

NOTICE

Ensure that the input (IN) and output (OUT) power cables of the optimizer are correctly connected. If they are reversely connected, the device may be damaged.

4.3.2 Measure optimizer voltage

Connect the positive probe of the Multimeter to the positive output terminal of the optimizer and the negative probe to the negative output terminal to check the output voltage of the optimizer.

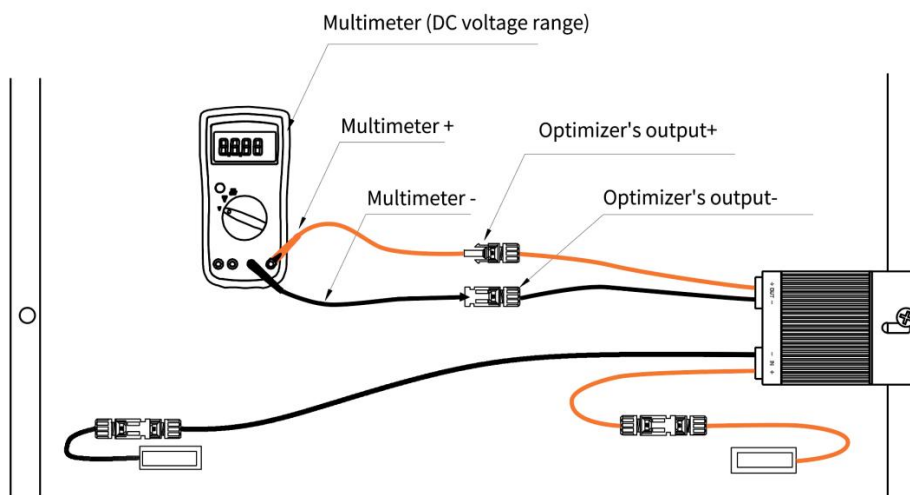

 **NOTE**

- When an optimizer is connected to a PV module, the typical output voltage of the optimizer is 1 V ($\pm 10\%$) in RSD mode.
- If the output voltage of an optimizer is abnormal, rectify the fault by referring to Table 4-1.

Table 4-1 Troubleshooting abnormal optimizer output voltage

Voltage	Cause	Suggestion
$V=1V(\pm 10\%)$	The optimizer is normal.	-
$V > 1V(\pm 10\%)$	<ul style="list-style-type: none"> ● The optimizer is faulty. ● The optimizer works in Normal mode. 	<ul style="list-style-type: none"> ● Execute RSD via the APP and re-measure the voltage. ● Replace the optimizer.
$V < 1V(\pm 10\%)$	<ul style="list-style-type: none"> ● The irradiance is low. ● The optimizer input cables are not connected. ● The optimizer cables are incorrectly connected. ● The optimizer is faulty. 	<ul style="list-style-type: none"> ● Measure the voltage when the irradiance is adequate. ● Correct the optimizer cable connections. ● Connect the optimizer input power cables to the PV module output power cables. ● If the voltage is still abnormal, replace the optimizer.
$V \approx -1V(\pm 10\%)$	<ul style="list-style-type: none"> ● The probes are reversely connected. 	<ul style="list-style-type: none"> ● Reconnect the positive and negative probes correctly.

4.4 Measure string voltage

After checking that the optimizers and their input power cables are properly connected, connect the optimizer output power cables. Measure the PV string voltage when the irradiance is adequate.

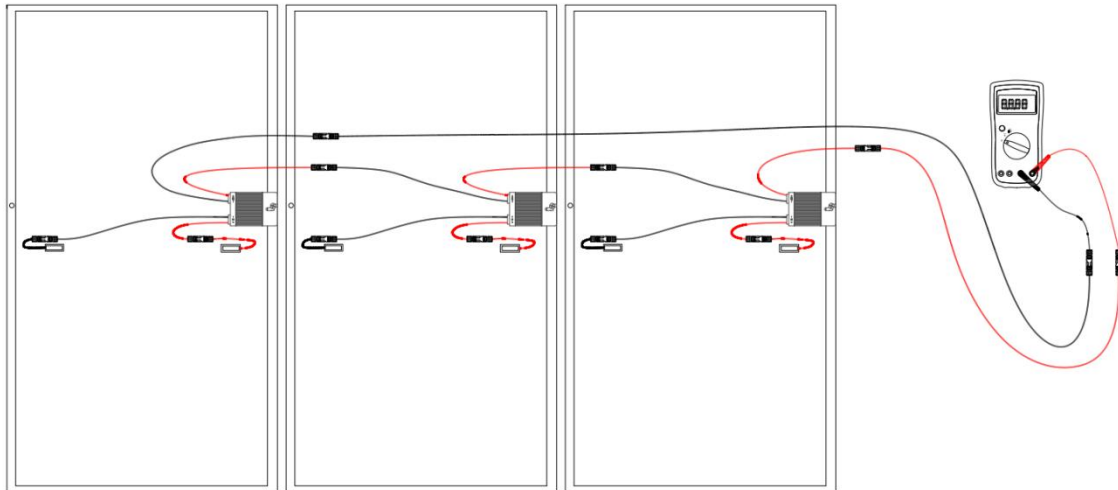

NOTE

PV string voltage = $V_1 + V_2 + \dots + V_N \approx N \times 1 \text{ V}$ (N=number of optimizers)

- When optimizers are connected to PV modules, the output voltage of each optimizer should be 1 V ($\pm 10\%$). Therefore, the voltage value of the PV string is approximately equal to the number of PV modules.
- If the PV string voltage is abnormal, rectify the fault by referring to Table 4-2.

Table 4-2 Troubleshooting abnormal PV string voltage

Voltage	Cause	Suggestion
$V=N*1 \text{ V}(\pm 10\%)$	<ul style="list-style-type: none"> ● The PV string is normal. 	-
$V \approx 0$	<ul style="list-style-type: none"> ● The PV string is open-circuited. ● The cables are not connected to the same PV string. 	<ul style="list-style-type: none"> ● Check whether the PV string is open-circuited. ● Identify the string cables correctly.
$V < 0$	<ul style="list-style-type: none"> ● The probes are reversely connected. ● The cable labels are incorrect. 	<ul style="list-style-type: none"> ● Reconnect the positive and negative probes correctly. ● Attach correct cable labels.
$0 < V < N*1 \text{ V}(\pm 10\%)$	<ul style="list-style-type: none"> ● Some optimizer input power cables are not connected. ● Some optimizer output power cables are not connected. ● Some optimizer output power 	<ul style="list-style-type: none"> ● Check whether PV modules and PV string cables are correctly connected.

	cables are reversely connected.	
$V > N * 1 V (\pm 10\%)$	<ul style="list-style-type: none"> The actual number of optimizers in the PV string is greater than expected. PV modules are directly connected to PV strings without being connected to optimizers. Partial optimizers work in Normal mode. 	<ul style="list-style-type: none"> Check whether the number of optimizers in the PV string is correct. Check whether PV modules and PV string cables are correctly connected. Execute RSD via the APP and re-measure the voltage.

4.5 Connect to the inverter

Connect cables between the PV string and the inverter.

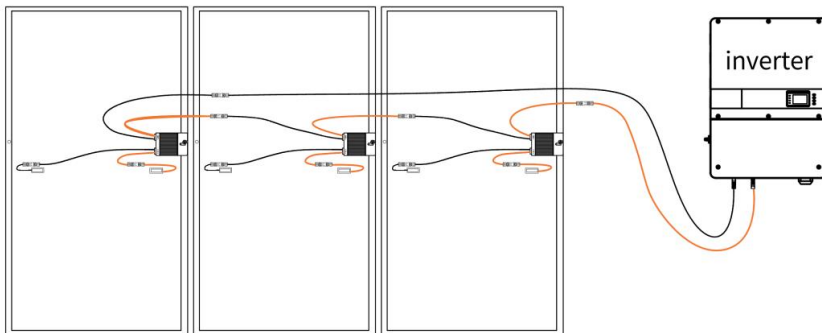

4.6 Generate Layout

After determining the optimizer installation location, remove the SN label from the optimizer and stick it on the physical layout template.

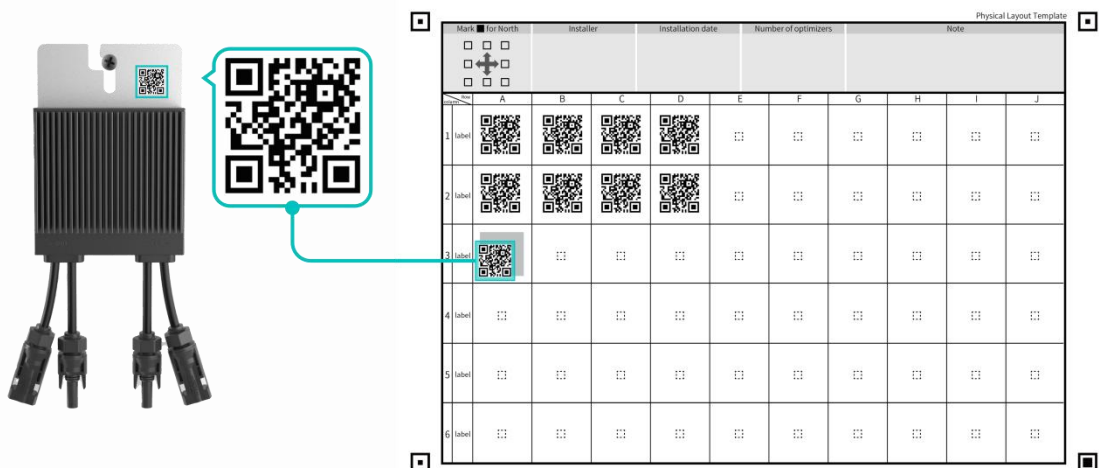

NOTE

When pasting a QR code, the following principles must be followed, otherwise the optimizer will

fail to recognize the QR code.

- Please stick the QR code flatly in the center of the frame without blocking the border;
- Multiple QR codes must not block or cover each other;
- When taking pictures, face the paper directly and ensure that the paper is flat, with the paper area accounting for more than 50% of the entire image area, and the background is a solid color to avoid QR code reflection;
- When taking pictures with a mobile phone, the shooting range needs to cover the entire layout card, that is, including the 4 positioning squares around the layout card.

If there are a large number of optimizers, you can use multiple templates to paste the QR codes according to the actual layout.

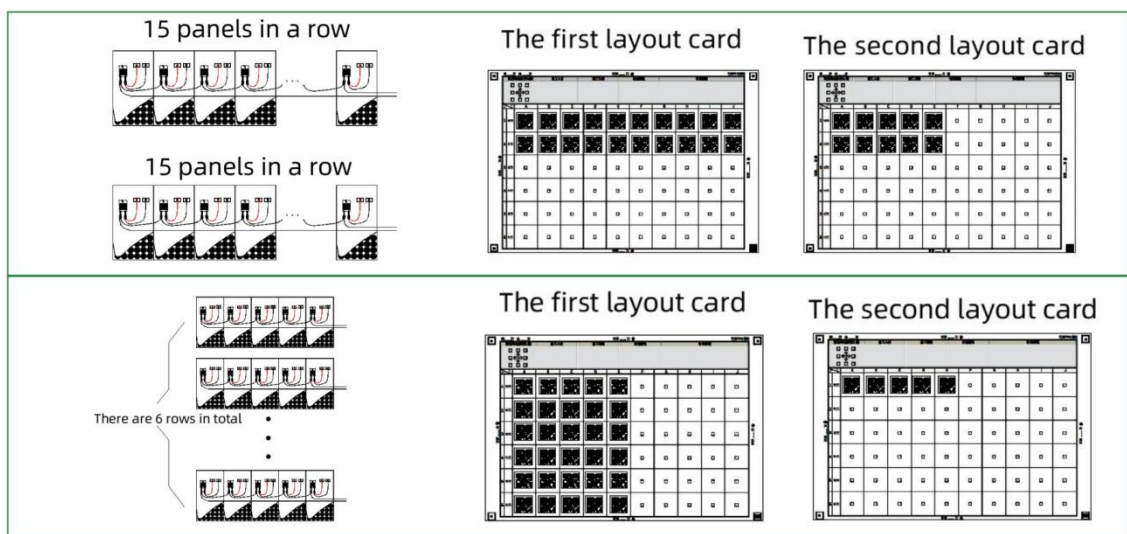

5 APP operation guide

5.1 Download the APP

Method 1: Download from APP Store & Google Play.

iPhone mobile phone users: search for "SolarPilot Energy" in the App Store.

Other mobile phone users: search for "SolarPilot Energy" in the application market.

Method 2: Download by scanning below QR code.

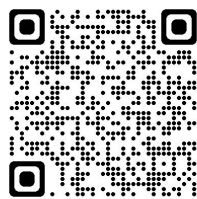

Android



IOS

Note: When you selecting "Browser download" method. If prompted "This application is from an unofficial app store..." and other prompts during the installation process, please click "Continue installation".

5.2 Registration and Login

Please follow the prompts, enter your mobile phone number or email account correctly and verify it. After passing the verification, complete the business information.

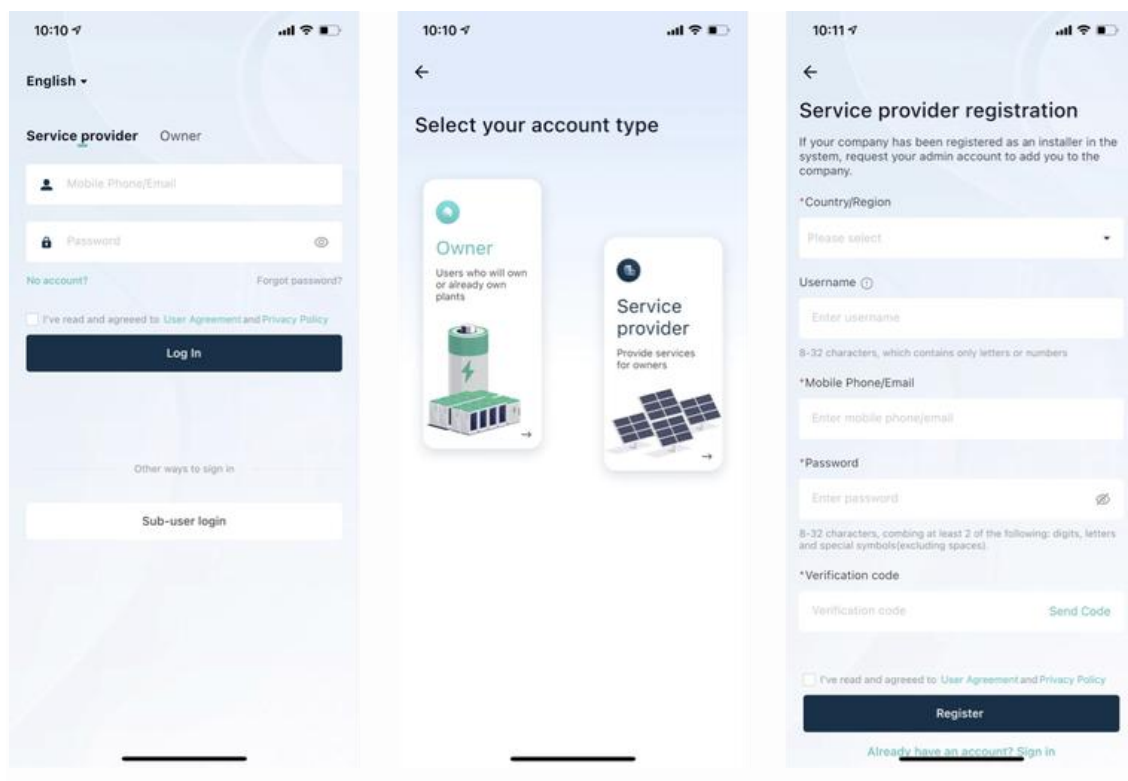

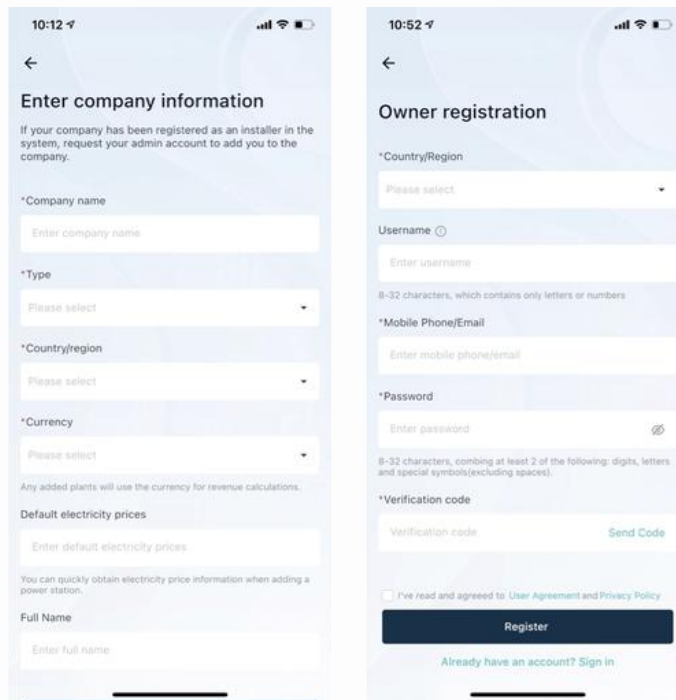

5.3 Create a Power Station

5.3.1 Enter the power station addition page

Log in to the account you just created, and click [Me] - [Plant Management] - [+] to enter the power station addition page.

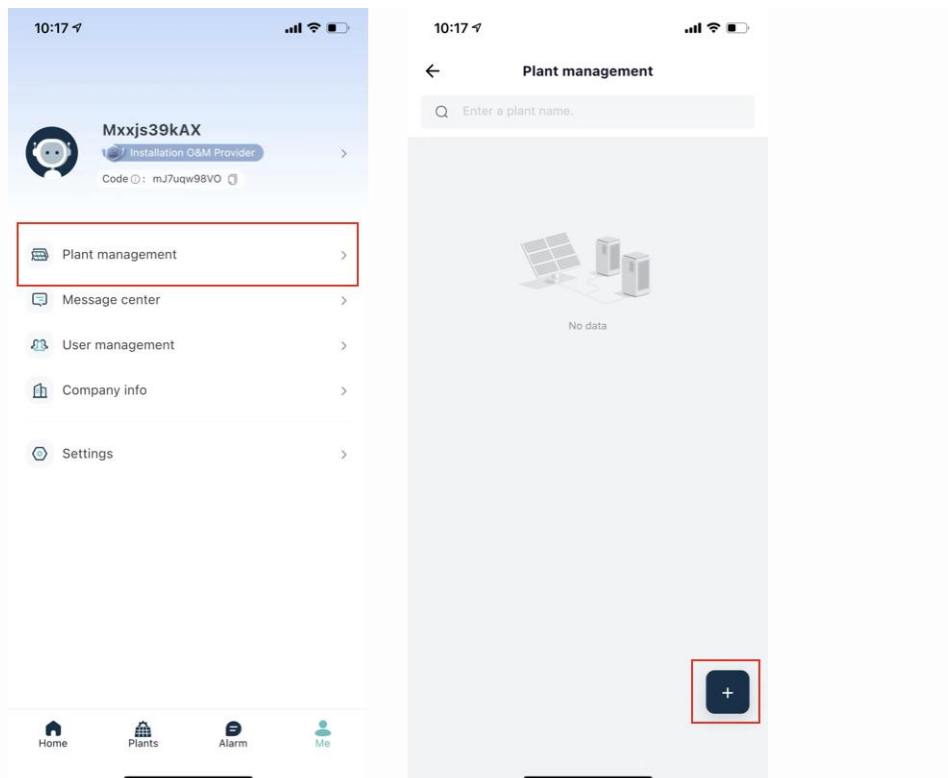

5.3.2 Improve the power station information

- 1) Please follow the prompts to improve the basic information of the power station: the name of the power station, the location of the power station, the area, the address, the installed power, etc. The fields indicated with an asterisk are required, and the more complete the rest of the information is, the better it is for you to manage the power station.

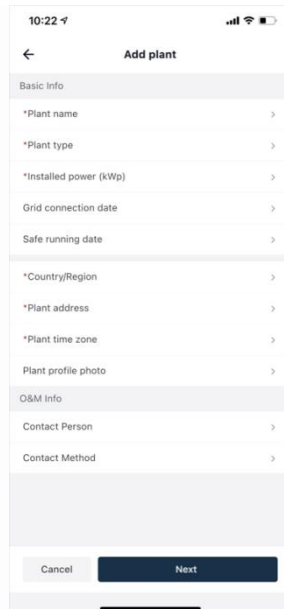

- 2) After completing the power station information, please click the [Next] button at the bottom of the page to complete the creation, and the system will enter the interface of Figure 1 below.
 - You can directly add devices and authorized users on the Power Station Creation Success page in Figure 1, or click the [Done] button in the upper right corner to skip device binding and authorization first.
 - Later, you can also directly in the power station management list interface (Figure 2 below), click the power station name to enter the main interface of the power station editor (Figure 3) to complete and supplement the information.

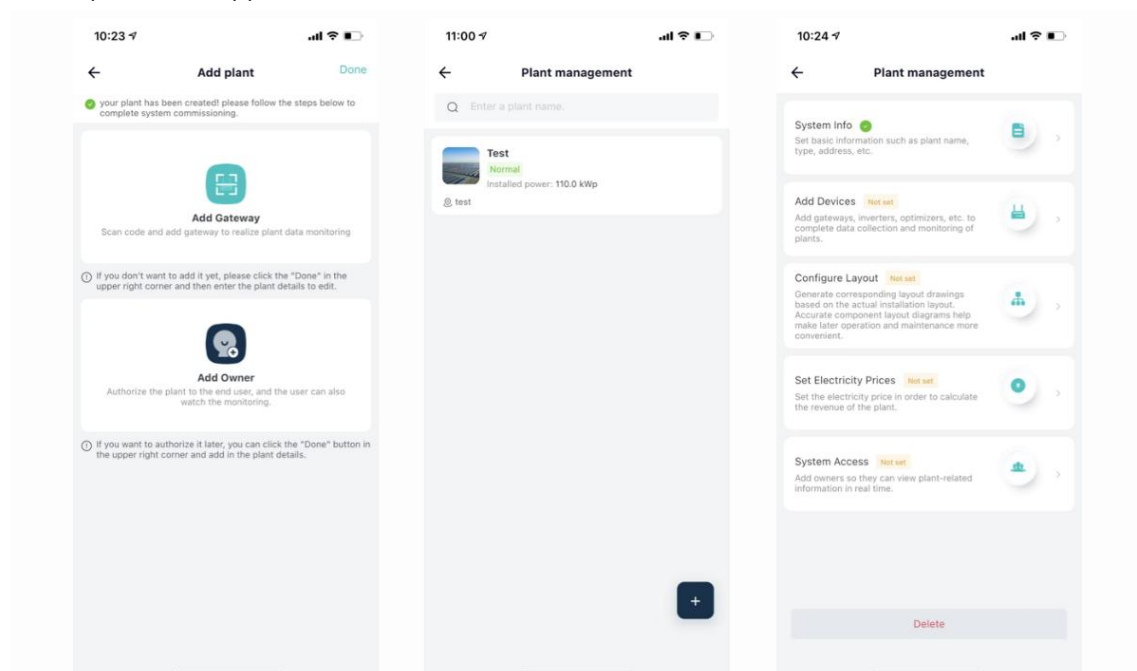

5.3.3 Configure the gateway

The SP1 gateway provides two modes: wired distribution network and AP distribution network, which can be flexibly selected according to the on-site environment.

- **Wired distribution network**

- 1) Enable the camera permission of the mobile phone: Click [Add Gateway] on the power station creation successfully completed page or click [Add Devices] on the main interface of power station editing, and the system will enter the code scanning interface. When using it for the first time, the page prompts that the permission of camera needs to be enabled, which is convenient for you to scan the code for identification.

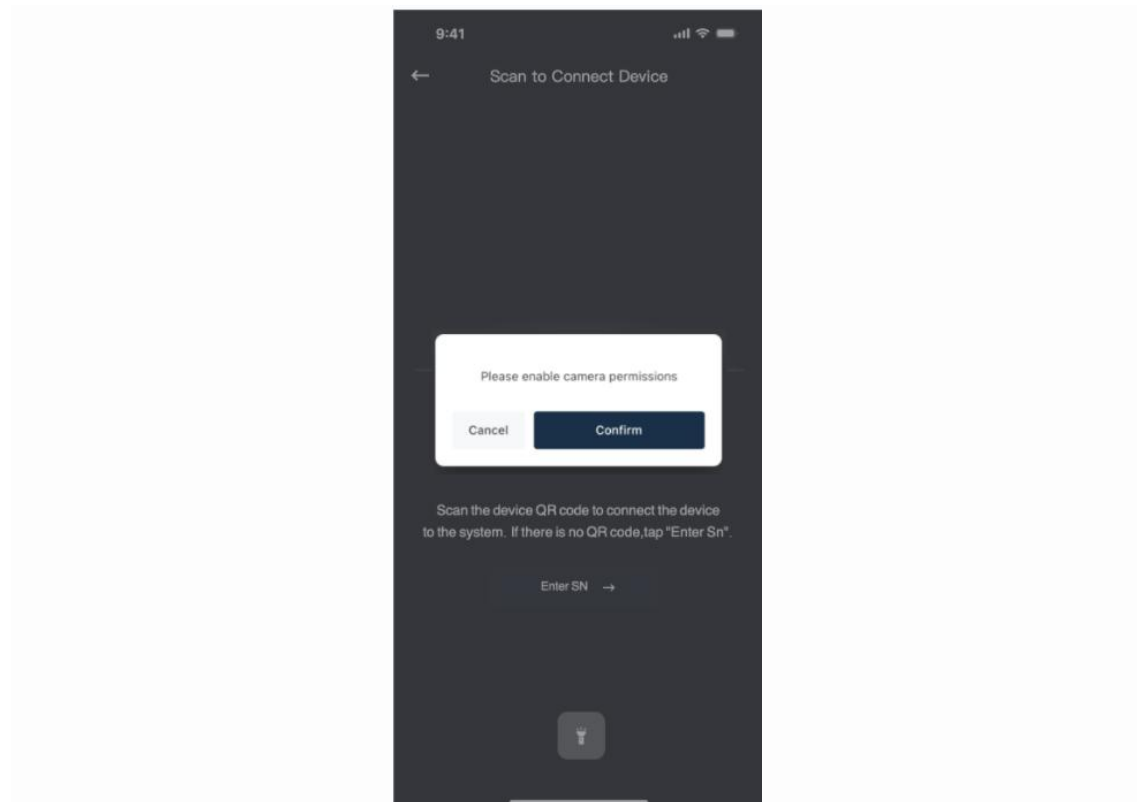

- 2) Reset the device: Connect the power supply, connect to the router via the Ethernet cable, and confirm that the indicators are as expected: LED1 and LED2 are always on.

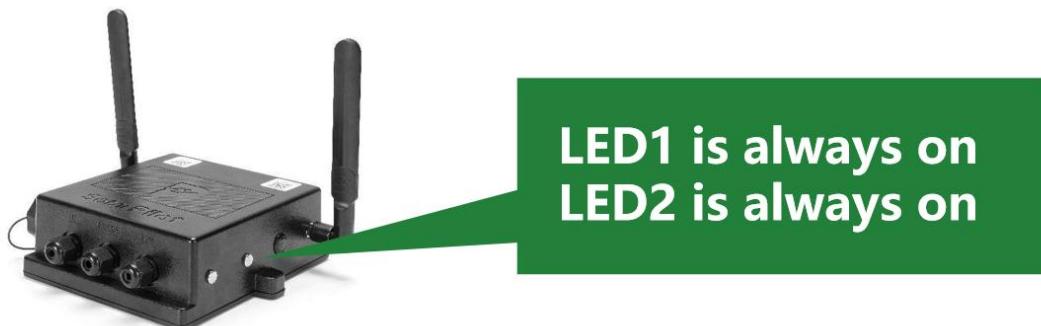

- 3) After completing the authorization and confirming that the device is connected to the Internet, you can choose to directly scan the barcode or QR code on the device to add it, or manually enter the serial number to add it.

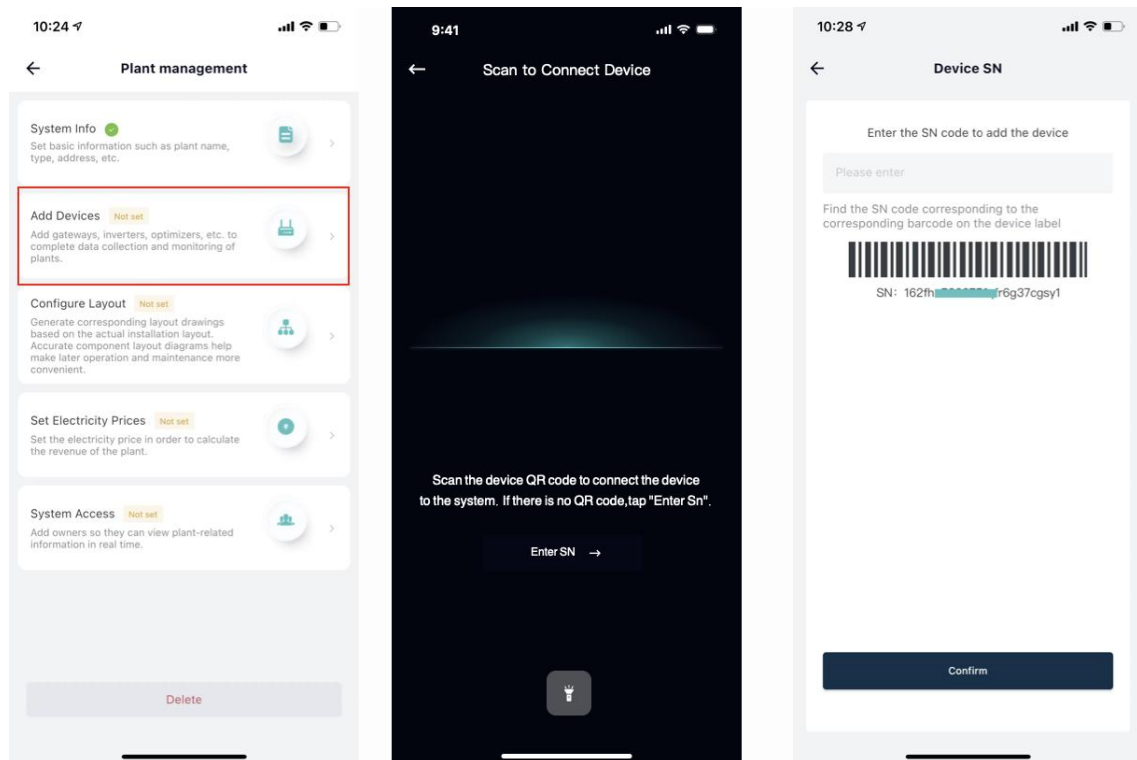

- 4) The device will enter the distribution network interface if the code is successfully scanned, and the distribution network will count down for 2 minutes.
- If the addition is successful, the system will enter the distribution network success interface . You can set the device name in the current interface. After setting the name, click the [Done] button to enter the main interface of the gateway.
 - If the gateway fails to be added, the system will enter the distribution network failure interface. Please check the device and network conditions. And the network distribution can be performed again after the device is reset.

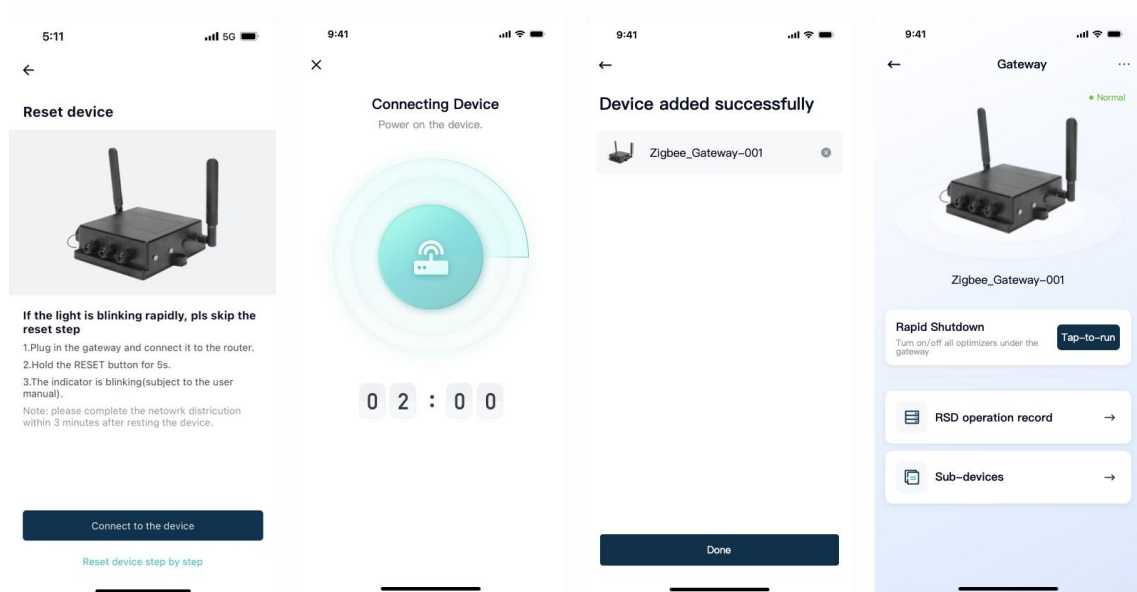

- AP distribution network

Please use 2.4G Wi-Fi for configuration in all the following network distribution processes. 5G Wi-Fi is not currently supported.

- 1) Press button for 3-10 seconds to activate the AP distribution network mode. After success, LED1 will flash slowly.

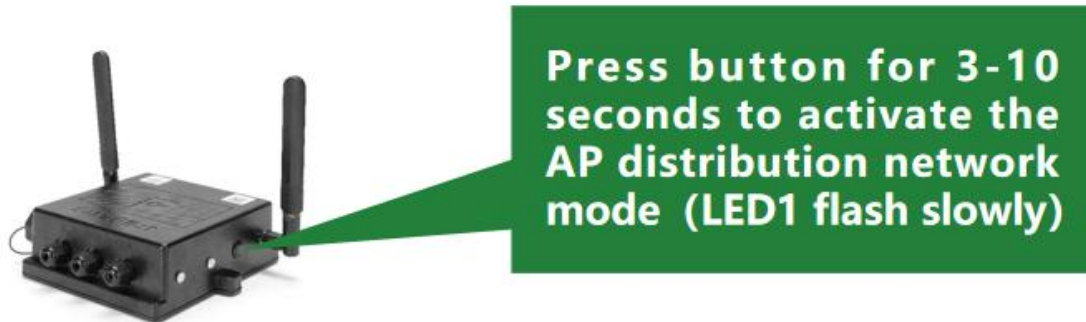

- 2) Enter the power station configuration device interface, select [Add Devices], and scan or enter the SN of the gateway to be configured. After finding the corresponding device, switch to Wi-Fi Mode as shown below.

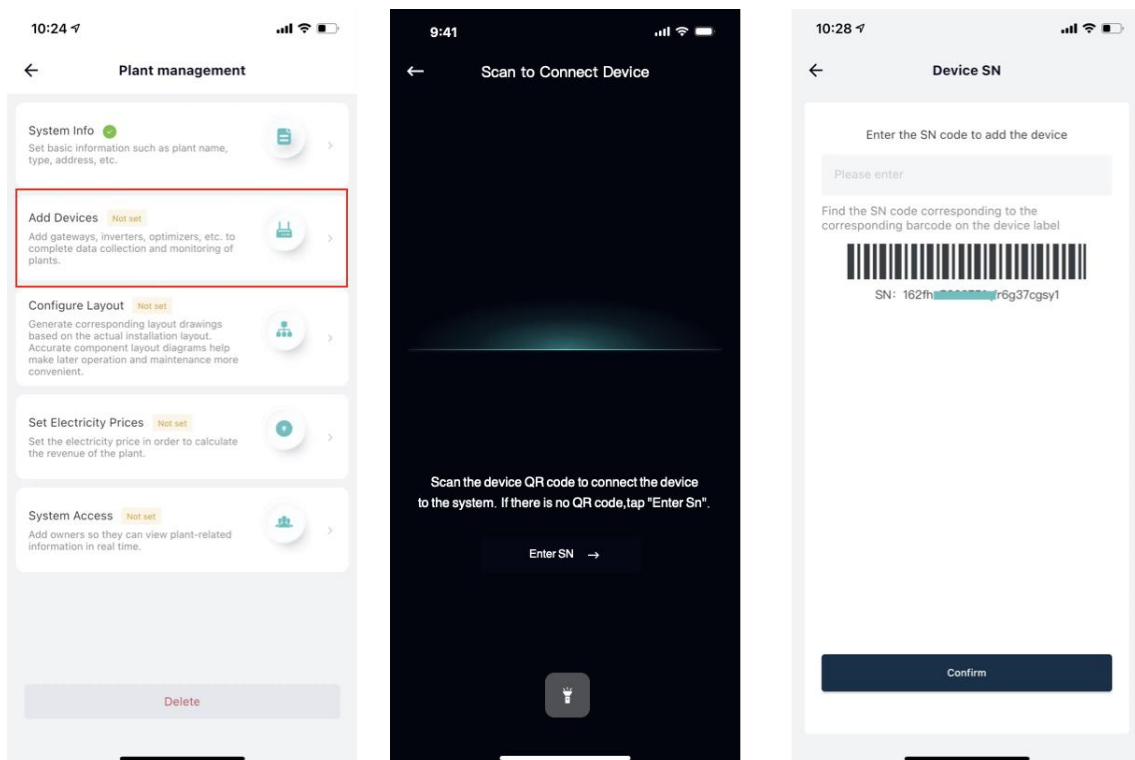

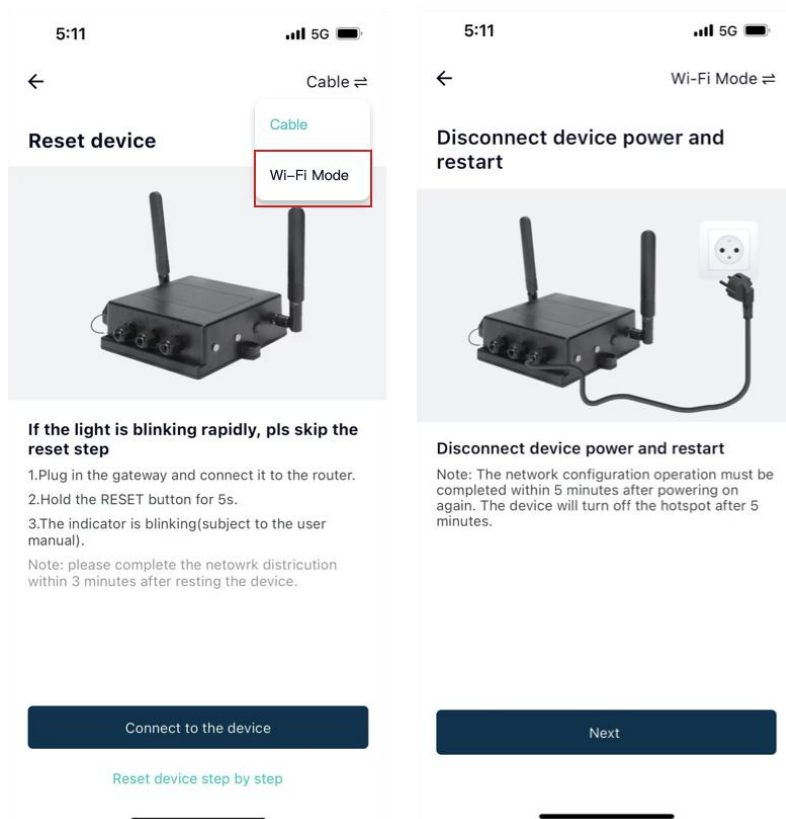

- 3) Please make sure your phone is connected to the 2.4G Wi-Fi, consistent with the network displayed on the page, and enter the password for that network. After completing the input and confirming that the information is correct, click the [Next] button.

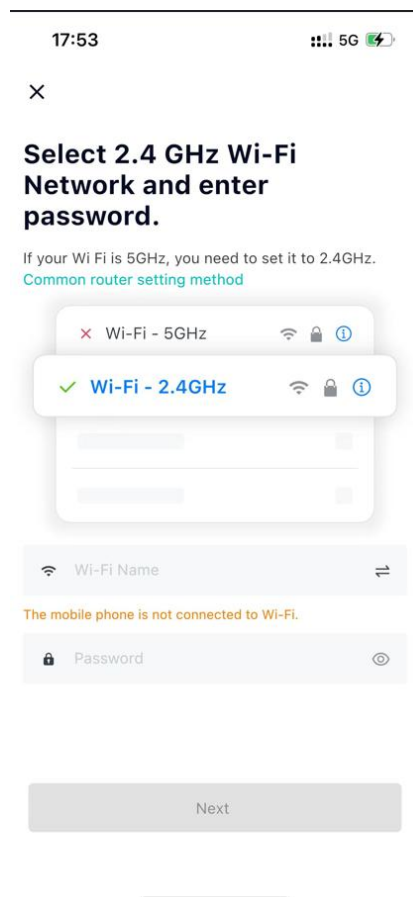

- 4) According to the instructions on the page, you now need to connect your phone to the network "SolarPilot_XXXXX". Please click the [Go to Connect] button and connect to this network in the "WLAN" page of the phone system. After successful connection, please return to the SolarPilot APP.

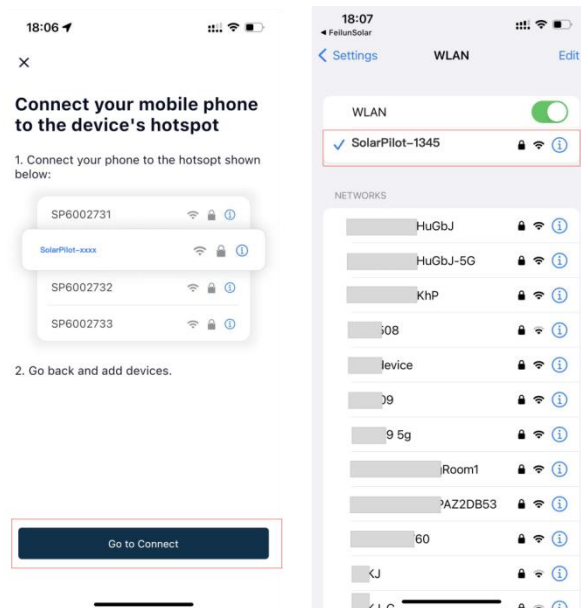

- 5) Wait for the configuration to complete.

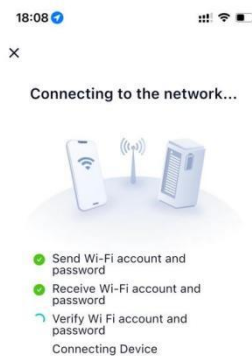

If the page prompts that the configuration fails, please check and try again according to the following possible reasons

1. Make sure your phone's WLAN is turned on
2. Confirm that the Wi-Fi network can access the Internet normally
3. Ensure that the wireless router does not enable the black and white list
4. Try to shorten the distance between your phone and device
5. Try connecting to another Wi-Fi network to reconfigure the network
6. Try removing special characters such as (, ; " = " " `) from the Wi-Fi network name

5.4 Add Layout

Select the gateway to which the optimizer needs to be configured, then use the camera to take a photo of the template with the QR code just pasted on it, and follow the instructions in the figure below to complete the optimizer layout generation.

Note: A gateway can have a maximum of 50 optimizers

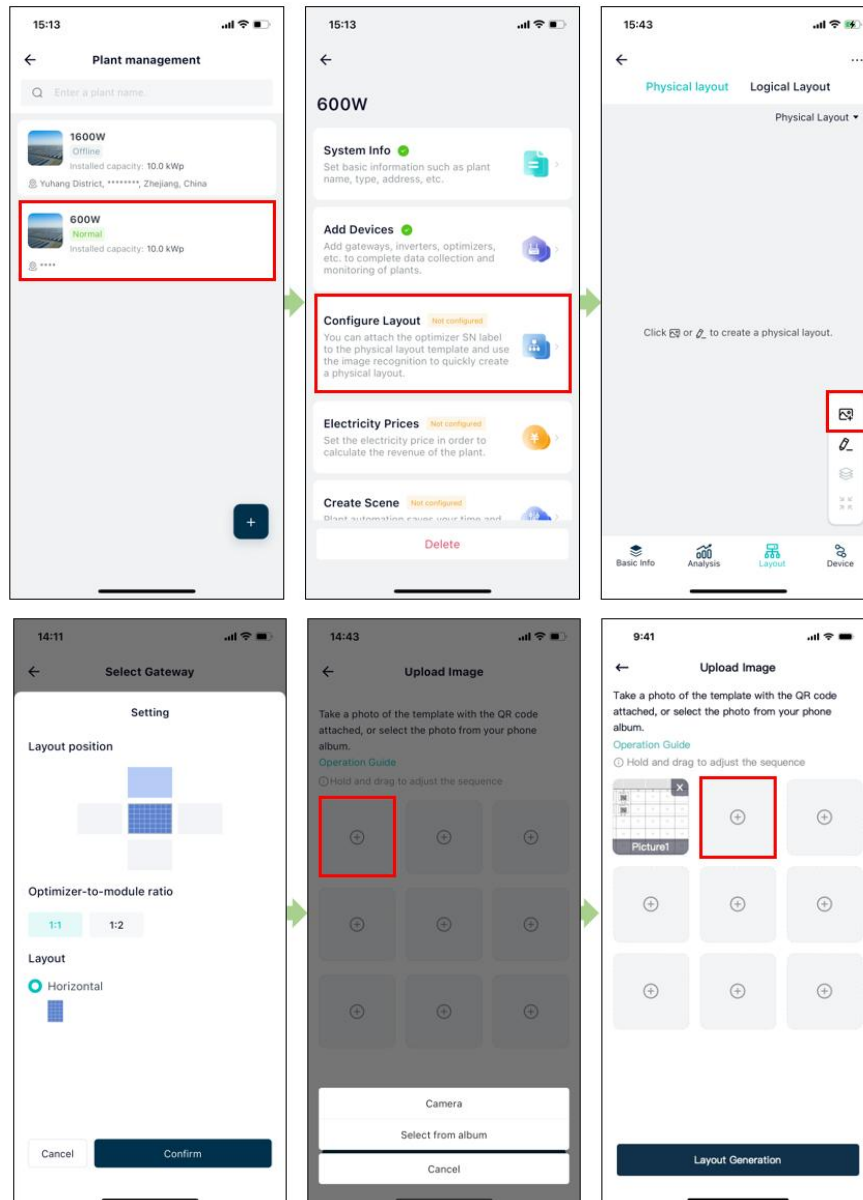

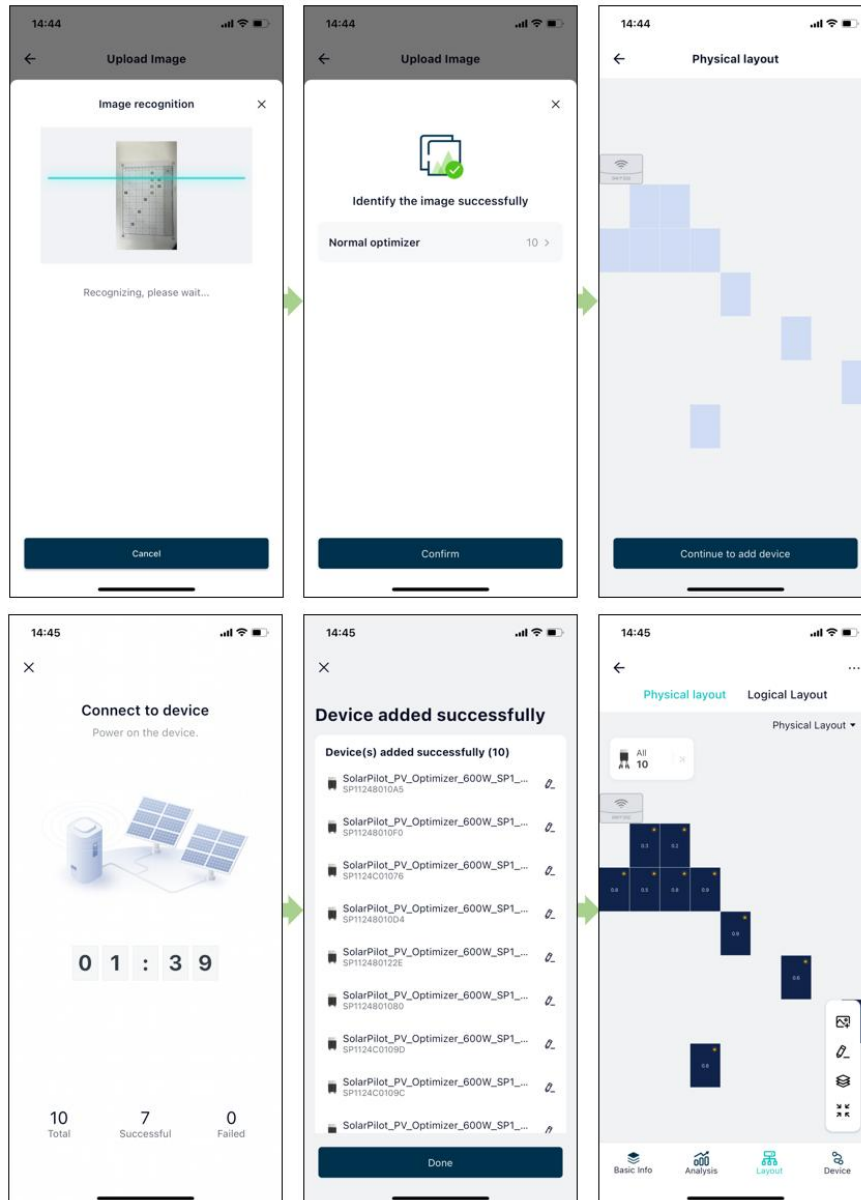

5.5 Improve the information

Improve the electricity revenue, owner information, etc. to facilitate better operation and maintenance of photovoltaic power stations.

Not required, if not used, you can ignore the following steps.

5.5.1 Set electricity price

Enter the revenue per kilowatt hour, and the system will calculate the revenue of the entire power station according to the unit price set here.

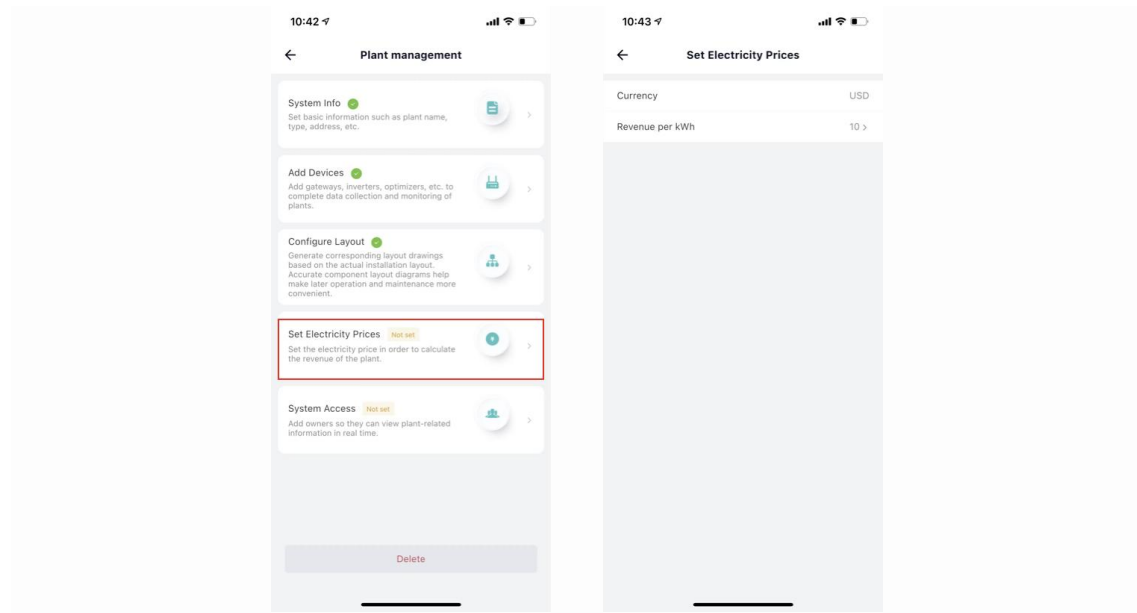

5.5.2 Add owner

Enter the owner account number and user name to complete the authorization operation of the power station.

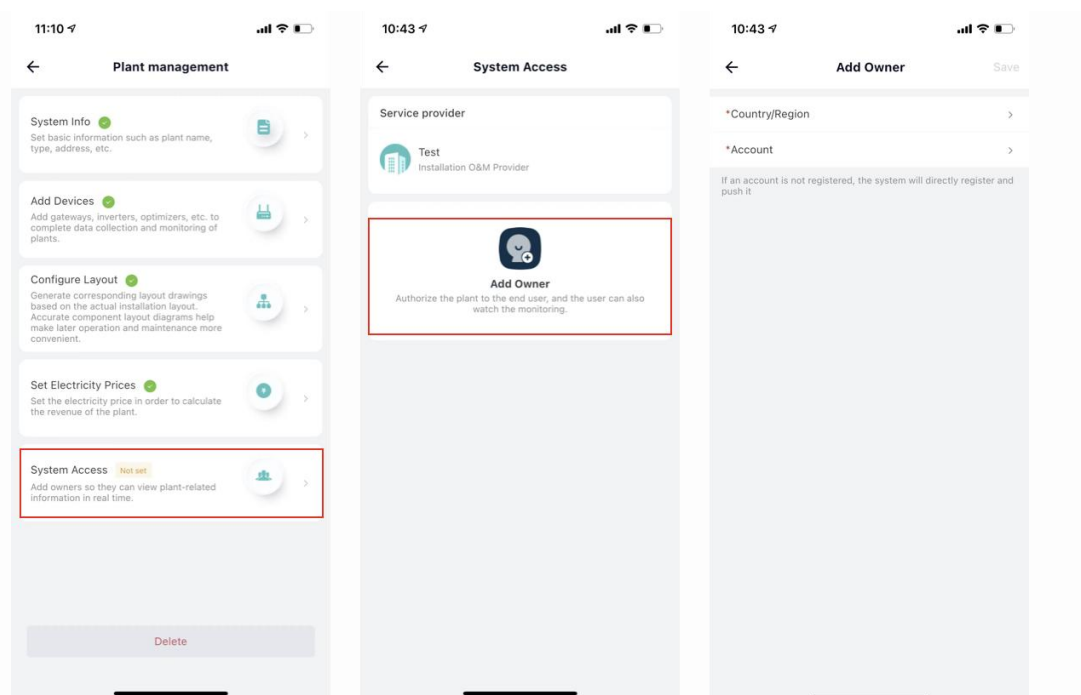

6 Practice Running

NOTICE

- All cables and accessories are connected properly and securely.
- The cables are reasonably distributed and well protected without mechanical damage.
- The vacant terminals are sealed.
- All safety signs and warning labels are firmly affixed and clearly visible.

6.1 Practice Running Steps

Step 1: Turn the DC switch on the inverter to "ON".

Step 2: If there is an AC switch between the inverter and the power grid, close the switch.

Step 3: If DC switch is provided between the inverter and the photovoltaic string, close the switch.

Step 4: When the irradiance is adequate and the grid conditions meet the grid requirements, the power station will operate normally.

6.2 Execute Recover Output(Very Important)

The optimizer works in RSD mode by default and needs to recover output.

Otherwise the PV system will work abnormally.

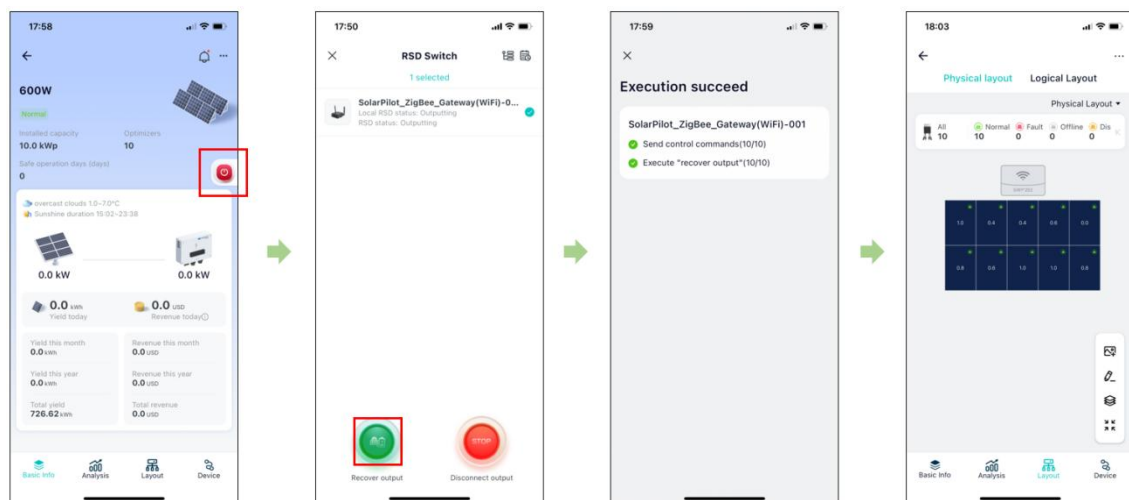

7 Troubleshooting

- Once the optimizer fails, the fault information can be displayed on the mobile App interface or the PC interface.
- The fault codes and troubleshooting methods of all optimizers are detailed in the table below. The model you purchased may only contain part of the fault information. When the optimizer fails, you can use the fault code or alarm name on the mobile App to carry out the corresponding information.

Fault code	Alarm name	Suggestions
0300	Input overvoltage	Check whether the optimizer input voltage exceeds 70V.
0303	Input overcurrent	Check whether the optimizer input current exceeds 15A.
0306	Short OverLoad	Check whether the maximum input power of the optimizer is greater than 600W.
0307	Long OverLoad	
0308	Output overtemperature	Check whether the ventilation of the installation location of the optimizer is good and whether the ambient temperature exceeds the maximum allowable ambient temperature range.
0309	Input overtemperature	
0310	MOS overtemperature	
0314	Output short circuit	Confirm the output cable connection.

8 Replace the Optimizer

NOTICE

- Please use special insulation tools, wear insulated shoes and insulated gloves before operating.
 - Prepare the new smart PV optimizer.
 - Prepare your phone with SolarPilot app.
-

- 1) Wear insulated gloves to disconnect the external AC circuit breaker and prevent re-connection due to misoperation.
- 2) Disconnect the external DC circuit breaker and turn the DC switch of the inverter to "OFF".
- 3) Execute disconnect output operation through APP to ensure that the string voltage is reduced to a safe range.
- 4) Use the current clamp to detect the DC cable and confirm that there is no current.
- 5) Disconnect the input and output terminal of the optimizer.
- 6) Remove the old optimizer.
- 7) Install the new optimizer and check if the output voltage is normal.
- 8) Use the APP to add a new optimizer and re-execute the recover output operation.
- 9) Re-power the inverter and observe the operating status of the PV system through the APP.

9 Technical Parameters

Product specification	SP1-600W-AS	SP1-600W-AL
Efficiency		
Maximum efficiency	≥99.5%	
European efficiency	≥99.0%	
DC input		
Maximum input power	600W	
Maximum input voltage	75V	
MPPT voltage range	15V ~ 75V	
Starting voltage	15V	
Maximum input current	15A	
DC output		
Maximum output power	600W	
Maximum output voltage	75V	
Maximum output current	18A	
Function		
Bypass cut-off function	YES	
Automatic shutdown function	YES	
Manual shutdown function	YES	
DC overvoltage protection	YES	
DC overload protection	YES	
Polarity reverse protection	YES	
Short circuit protection	YES	
Wireless data collection	YES	
Detection accuracy		
Voltage	0.01V	
Current	0.01A	

General parameters	
Dimensions	95mm*129mm*56mm
Net weight	≤1000g
Ingress protection	IP68
System voltage	1100V
Data sampling interval	1 min (I/V/P) / 5min / 15 min
Data transmission distance	≤50m(outdoor)
	≤30m(indoor)
DC input/output connector	MC4
Input DC cable length	0.12m 1.0m
Output DC cable length	1.2m
Operating temperature	-40°C ~ 85°C
Storage temperature	-40°C ~ 70°C
Operating humidity	0% ~ 100%
Operating altitude	≤2000m
Power supply	PV panel
Shutdown time	≤10S
Installation method	Fixed on bracket/PV panel frame

Appendix A: Contact Information

If you have technical questions concerning our products, please contact our support through SolarPilot web service portal: www.solarpilot.com/support

Region	Country	Email	Tel.

Appendix B: Acronyms and Abbreviations

D	
DC	direct current
E	
EFT	electrical fast transient
EMI	electromagnetic interference
EMS	electromagnetic susceptibility
ESD	electrostatic discharge
M	
MPPT	maximum power point tracking
R	
RE	radiated emission
RS	radiated susceptibility



If you have technical queries concerning our products,
please contact us:

Address: Arndtstrasse 27b, 22085 Hamburg, Germany

E-mail: info@solarpilot.com

Website: <https://www.solarpilot.com>